

Supporting Document 3

Leachate Treatment Alternatives – Assessment and Evaluation Methodology





Waste Management of Canada Corporation

West Carleton Environmental Centre Landfill Footprint Expansion

LEACHATE TREATMENT ALTERNATIVES – ASSESSMENT AND EVALUATION METHODOLOGY

Prepared by:

AECOM Canada Ltd.

Project Number:

60242342

Date:

August, 2012

Table of Contents

	Page
1. Overview of Leachate Treatment Alternatives	1
1.1 Background.....	1
1.2 Report Objective	1
2. Considerations for Leachate Treatment Alternatives	2
2.1 Leachate Control.....	2
2.2 Leachate Generation Rate	2
2.3 Leachate Quality	3
2.4 Leachate Pretreatment	5
2.4.1 Equalization.....	5
2.4.2 Biological Treatment.....	6
2.4.3 Chemical Treatment	7
2.4.4 Filtration	8
2.4.5 Reverse Osmosis	8
2.4.6 Granular Activated Carbon Adsorption	8
3. Description of Leachate Treatment Alternatives	9
3.1 On-site Tree Irrigation	10
3.1.1 Feasibility and Reliability	11
3.1.2 Regulatory Considerations	11
3.1.3 Environmental Considerations.....	11
3.1.4 Capital and Operating Costs.....	12
3.2 On-site Leachate Evaporation.....	12
3.2.1 Feasibility and Reliability	13
3.2.2 Regulatory Considerations	14
3.2.3 Environmental Considerations.....	14
3.2.4 Capital and Operating Costs.....	14
3.3 Off-site Effluent Discharge to Surface Water	14
3.3.1 Feasibility and Reliability	16
3.3.2 Regulatory Considerations	16
3.3.3 Environmental Considerations.....	17
3.3.4 Capital and Operating Costs.....	17
3.4 Off-site Effluent Discharge to City of Ottawa Sanitary Sewer	17
3.4.1 Feasibility and Reliability	18
3.4.2 Regulatory Considerations	18
3.4.3 Environmental Considerations.....	18
3.4.4 Capital and Operating Costs.....	18
3.5 Truck Haulage Off-site to Alternative Wastewater Treatment Plant.....	19
3.5.1 Feasibility and Reliability	19
3.5.2 Regulatory Considerations	20
3.5.3 Environmental Considerations.....	20





3.5.4	Capital and Operating Costs.....	20
4.	Evaluation of Leachate Treatment Alternatives	21
4.1	Evaluation Methodology.....	21
4.2	Evaluation Results	22
4.2.1	Option #1 – On-site Tree Irrigation	22
4.2.2	Option #2 – On-site Leachate Evaporation	29
4.2.3	Option #3 – Off-site Effluent Discharge to Surface Water	29
4.2.4	Option #4 – Off-site Effluent Discharge to City of Ottawa Sanitary Sewer.....	29
4.2.5	Option #5 – Truck Haulage Off-site to Alternative Wastewater Treatment Plant.....	30
4.3	Comparative Evaluation of Leachate Treatment Alternatives	30
4.3.1	Overall Ranking.....	30
4.3.2	Sensitivity Analysis.....	30
4.4	Preferred Alternative	33

List of Figures

- Figure 1. Preferred Landfill Footprint and Surrounding Area
- Figure 2. On-site Tree Irrigation
- Figure 3. On-site Leachate Evaporation
- Figure 4. Off-site Effluent Discharge to Surface Water
- Figure 5. Off-site Effluent Discharge to City of Ottawa Sanitary Sewer
- Figure 6. Truck Haulage Off-site to Alternative Wastewater Treatment Plant

List of Tables

- Table 1. Raw Leachate Characteristics, Conventional and Other Frequently Monitored Parameters at the Existing Ottawa WMF.....4
- Table 2. Raw Leachate Characteristics at the Existing Ottawa WMF, January 2010 Comprehensive Analysis.....4
- Table 3. Estimated Air Emissions*, On-Site Evaporator Treatment..... 13
- Table 4. Comparative Evaluation of Leachate Treatment Alternatives

Appendices

- Appendix A. Facility Sizing Calculations



1. Overview of Leachate Treatment Alternatives

1.1 Background

Waste Management of Canada Corporation (WM) is preparing an Environmental Assessment (EA) for a proposed undertaking consisting of the provision of a new landfill footprint at the existing Ottawa Waste Management Facility (Ottawa WMF). The new landfill footprint will be one component of the proposed West Carleton Environmental Centre (WCEC). The existing Ottawa WMF landfill is located on Lots 3 and 4, Concession 3 in the former Township of Huntley, formerly in the Township of West Carleton, now the City of Ottawa near the intersection of Carp Road and Highway 417.

WM has undertaken and received approval of a Terms of Reference (ToR) to carry out an EA intended to identify and assess a new landfill footprint as part of the WCEC. During the formal review of the proposed ToR for an Environmental Assessment of a New Landfill Footprint at the West Carleton Environmental Centre, a number of comments were received from various government agencies and the public. Specifically, the City of Ottawa and the Ministry of Environment (MOE) requested that WM consider “alternative methods” for treating and disposing of leachate generated from the new landfill footprint. In response to this request, WM amended the proposed ToR to reflect that leachate treatment alternatives would be considered and assessed as part of the EA.

A preferred leachate treatment alternative will be identified following the identification of the preferred landfill footprint alternative (Option 2). The location of the preferred landfill footprint and surrounding area is shown in **Figure 1**.

1.2 Report Objective

This document presents background information on the requirement to collect and control leachate, projected leachate volumes and quality, a description of the proposed leachate treatment alternatives, a qualitative assessment of the alternatives, and identification of a preferred approach to leachate disposal for the new landfill footprint.

The leachate treatment alternatives have been described to a conceptual level of detail to enable a comparative analysis. The descriptions have focused on identifying characteristics that could be used to differentiate the alternatives from one another. The preferred leachate treatment alternative will be described in further detail as part of the detailed impact assessment of the undertaking.



2. Considerations for Leachate Treatment Alternatives

2.1 Leachate Control

The landfill leachate collection and treatment system for the new landfill footprint must be designed in accordance with the requirements of Ontario Regulation 232/98 (O.Reg. 232/98). In addition, the MOE's Reasonable Use Guideline B-7 must be met. The Reasonable Use Guideline sets limits for the allowable concentrations of contaminants based on background groundwater quality and the reasonable use of groundwater on adjacent property. The limits are set such that there would not be any significant effect on the use of groundwater on the adjacent property. O.Reg. 232/98 allows for two approaches to designing a landfill to protect groundwater quality – a site specific design, or a generic design. The site specific approach allows a proponent to design the leachate controls to suit the site setting provided that the Reasonable Use limits are met. The generic approach allows the proponent to select one of two generic designs which have been developed such that the Reasonable Use limits are met within a broad range of hydrogeologic settings.

At this time WM is planning to design the new landfill footprint with the Generic II – Double Liner system as specified in the O.Reg. 232/98. This consists of (from top down):

- 0.3 m thick granular/perforated pipe primary leachate collection system;
- 0.75 m thick geomembrane/engineered clay primary liner;
- 0.3 m thick granular/perforated pipe secondary leachate collection system;
- 0.75 m thick geomembrane/engineered clay secondary liner;
- 1 m thick natural or constructed soil attenuation layer.

The raw leachate collected within the landfill will be pumped from the primary drainage/leachate collection system. The potential location and size of leachate pumping station(s) required will be identified as part of the conceptual design for the preferred landfill footprint. Leachate will then be directed to treatment facilities in a manner dependent on the preferred leachate treatment alternative.

2.2 Leachate Generation Rate

The quantity and rate at which leachate is generated from the landfill are expected to be important factors in assessing the ability of a specific treatment alternative to manage the leachate on an ongoing basis. The volume of leachate to be managed will vary over the operational and post-closure period of the landfill and is influenced by factors including precipitation, degree of landfill



development (e.g., area of landfill that is actively undergoing development versus areas where final cover has been placed), final cover design and cover installation progress, and other factors.

For the purposes of describing the proposed leachate treatment alternatives, a series of leachate generation rates has been calculated based on the following:

- Leachate generation rates vary according to the size of the landfill footprint and the preferred landfill footprint area is approximately 36 ha;
- Increased volumes of leachate will be generated during the operating period for the landfill based upon the area of waste without final cover. The volume of leachate generated will decrease when the landfill footprint is fully closed;
- The final cover design is reflective of the minimum design specified in O.Reg. 232/98, consisting of 0.6 m of compacted fine-grained soil overlain by a 0.15 m thick vegetative layer in order to limit infiltration to 150 mm/year; and,
- Leachate generation rates for the preferred landfill footprint were estimated using the Hydrologic Evaluation of Landfill Performance (HELP) model for predicting hydrologic processes, testing the effectiveness of landfill designs, and assigning groundwater recharge rates. Additional information regarding the HELP modeling can be found in the Facility Characteristics Report (FCR) for the preferred landfill footprint alternative. The FCR is included as Supporting Document 4 to this EA.

Leachate generation rates during the landfill operating period will vary and will be higher than in the closed state. The approximate maximum leachate generation rate (expressed as an annual average) during the landfill operating period is estimated to be 5.1 litres per second (L/s). It is estimated that for the preferred landfill footprint alternative, the maximum leachate generation in the post closure period will range from 1.8 to 2.7 L/s. To optimize the size of required facilities and infrastructure, WM intends to manage leachate in a manner that minimizes the volume generated and is consistent with the volumes projected at closure. For planning purposes, and the consideration of leachate treatment alternatives, the estimated maximum rate of 5.1 L/s will be used. The derivation of these leachate generation rates is detailed in the FCR.

2.3 Leachate Quality

Typical leachate characteristics were determined from sampling and analysis of the leachate currently generated at the existing Ottawa WMF. **Table 1** provides a summary of frequently monitored wastewater parameters from several sampling events conducted in late 2009 and early 2010. **Table 2** provides a summary of a comprehensive analysis of a leachate sample collected in January 2010. The leachate quality data are typical of other operating landfill sites and reflect leachate strength with approximately maximum concentration values, given that the landfill has been operating since the 1960s.



Table 1. Raw Leachate Characteristics, Conventional and Other Frequently Monitored Parameters at the Existing Ottawa WMF

Parameter (mg/L)	Sample Date								No. Samples	Average	Maximum	Minimum
	27-Nov-09	03-Dec-09	09-Dec-09	16-Dec-09	23-Dec-09	05-Jan-10	18-Jan-10	29-Jan-10				
Ammonia	1,400	1,200	1,600	1,500	1,400		1,300	1,200	7	1,371	1,600	1,200
20-day BOD	2,500						3,500		2	3,000	3,500	2,500
Total BOD ₅	1,400	930	2,000	2,300	1,500	1,600	1,600	1,200	8	1,566	2,300	930
Dissolved BOD ₅	1,290		1,850		950		376		4	1,117	1,850	376
Total COD	4,600	3,400	7,400	6,900	5,100		6,300	4,900	7	5,514	7,400	3,400
Dissolved COD	4,000		3,840		3,910		5,710		4	4,365	5,710	3,840
Total TKN	1,700		1,700		1,500	1,800	1,400		5	1,620	1,800	1,400
Dissolved TKN	1,600		1,700		1,500		1,400		4	1,550	1,700	1,400
Total Phosphorus	14	8	14	13	26	12	11	11	8	14	26	8
Orthophosphate	10		2		5		6		4	6	10	2
pH	7.8	7.8	7.6	7.5	7.7	7.5	7.6	7.6	8	7.6	7.8	7.5
TSS	75	130	160	350	66	140	160	69	8	144	350	66
Alkalinity (as CaCO ₃)	7,710	6,910	8,050	8,450	8,070		7,100	7,370	7	7,666	8,450	6,910
Chloride	2,500	2,400	2,900	2,800	2,700		2,300	2,400	7	2,571	2,900	2,300
Zinc	0.610		3.600		0.830		0.850		4	1.473	3.600	0.610

Table 2. Raw Leachate Characteristics at the Existing Ottawa WMF, January 2010 Comprehensive Analysis

Parameter	Units	Concentration
pH	std. units	7.5
Phenols-4AAP	mg/L	0.22
Sulphide	mg/L	4.2
Total BOD ₅	mg/L	1,600
Total TKN	mg/L	1,800
Total Phosphorus	mg/L	12
TSS	mg/L	140
Methane	mg/L	2
Methane	L/m ³	3
DETECTED METALS (Total)		
Aluminum	µg/L	1,900
Antimony	µg/L	13
Arsenic	µg/L	63
Boron	µg/L	16,000
Cadmium	µg/L	1
Chromium	µg/L	220
Cobalt	µg/L	87
Lead	µg/L	28
Manganese	µg/L	780
Molybdenum	µg/L	30
Nickel	µg/L	320
Tin	µg/L	48
Titanium	µg/L	330
Vanadium	µg/L	47
Zinc	µg/L	2,400

Parameter	Units	Concentration
DETECTED ORGANICS		
Phenanthrene	µg/L	2
Naphthalene	µg/L	10
Bis(2-ethylhexyl)phthalate	µg/L	65
Benzene	µg/L	6
Chlorobenzene	µg/L	7
1,4-Dichlorobenzene	µg/L	22
cis-1,2-Dichloroethylene	µg/L	6
Ethylbenzene	µg/L	40
Toluene	µg/L	120
1,3,5-Trimethylbenzene	µg/L	7
p+m-Xylene	µg/L	90
o-Xylene	µg/L	40
Xylene	µg/L	130
Aroclor 1242	µg/L	1.70
Aroclor 1254	µg/L	0.23
Aroclor 1260	µg/L	0.13
Total PCBs	µg/L	2.06



The analyses of the existing Ottawa WMF leachate illustrate that the leachate contains relatively high concentrations of chemical oxygen demand (COD), biochemical oxygen demand (BOD), and nitrogen (total Kjeldahl nitrogen and ammonia). It has a neutral to slightly alkaline pH, and relative high concentrations of alkalinity. The leachate also contains relatively low concentrations of several metals and organic compounds.

2.4 Leachate Pretreatment

In order to meet applicable regulatory standards and requirements, it may be necessary to pretreat or fully treat leachate in order to implement various alternative methods to dispose of leachate. The specific requirements for pretreatment will depend on the leachate quality/quantity and the preferred leachate treatment alternative. For example, disposing of leachate via discharge to surface water will require a significantly greater level of pretreatment compared to disposal via evaporation. The pretreatment process is an interim step in the overall leachate treatment process but is not capable of being the ultimate method for managing and/or disposing of the landfill leachate generated. Leachate constituents that may require removal through pretreatment include oxygen demand as measured by COD (chemical) and BOD (biological); nutrients, including nitrogen and phosphorus; individual organic compounds; and metals. Pretreatment is typically undertaken through biological and physical/chemical processes of which there are many variations and combinations that can achieve the desired treated effluent quality.

The following is a description of a typical pretreatment process train that might be used including the primary purpose of each process step. The pretreatment process train that may be associated with each of the leachate treatment alternatives is shown in the schematic process flow figure for each alternative in the subsequent section of this document. The most appropriate pretreatment process train is best identified at the design stage for the preferred leachate treatment alternative.

2.4.1 Equalization

As described previously, the volume of leachate generated will be influenced by a number of factors and is expected to fluctuate during the operating life of the landfill. Equalization, provided by means of a storage tank or pond, allows any fluctuations in leachate generation to be evened out or balanced to buffer the daily and seasonal high and low leachate flow rates. The treatment equipment performs most effectively when the leachate flow rate is consistent.

Typically, equalization is sized to provide two to five days of storage at the average leachate flow rate. Therefore, the required equalization volume would range up to 2,200 cubic metres at the projected maximum annual average leachate generation rate (i.e. 5.1 L/s). Equalization can



be provided via an above-grade steel tank constructed within secondary containment. A benefit of a storage tank is that it is enclosed to minimize odour generation at the facility and heat is retained which is important for biological activity.

2.4.2 Biological Treatment

Aerobic biological treatment is commonly used to reduce concentrations of COD and BOD, as well as nitrogen compounds from leachate. Microorganisms utilize the organic and nitrogen compounds in the leachate as a substrate, or food source, and nutrients such as nitrogen and phosphorus are used during the metabolism process, and incorporated into the biomass. The products of the microbial metabolism are carbon dioxide, water, and additional microbial cell mass. Excess microorganisms must be periodically removed from the system and disposed either in the landfill or off-site.

A variety of fixed film and suspended growth processes are available to accomplish the biological treatment process. One of the most common biological processes used for pretreatment of leachate is a variation of the activated sludge process known as a sequencing batch reactor, or SBR. This process has been widely used by WM and it provides reliable treatment for removal of COD, BOD and nitrogen. Treatment takes place in one or more tanks containing suspended-growth microorganisms. The tank(s) are equipped with mixing and aeration systems to provide adequate contact between the microorganisms and leachate, and to provide oxygen necessary to satisfy the microbial requirements for aerobic metabolism of the organic and nitrogen compounds contained in the leachate.

Leachate is treated in batches, and a control system automatically controls the sequence of stages that take place during treatment of each batch of leachate, as described below.

- **Mixed Fill** – leachate is pumped into the SBR reactor. Mixing is initiated to enhance the contact between the leachate and the microorganisms.
- **Aerated Fill** – aeration is initiated to provide oxygen for the microorganisms.
- **Aeration** – aeration continues until treatment objectives for the leachate batch are met, determined either by treatment time or automated monitoring of leachate constituents.
- **Settle** – aeration and mixing are discontinued, allowing the microorganisms to settle to the bottom of the SBR reactor.
- **Decant** – treated leachate liquid is poured off or decanted from near the surface of the SBR reactor for further treatment or discharge, leaving the settled solids to be removed from the bottom of the reactor.



The control system typically allows operator control of the treatment sequence and times for various stages, providing a great deal of flexibility in treatment to respond to changing leachate characteristics or treatment objectives.

Nitrification is the biological process used to convert organic and ammonia-nitrogen to oxidized forms of nitrogen, such as nitrate. The organisms used in the nitrification process are slow-growing and temperature sensitive; therefore, to ensure adequate treatment during periods of cold temperatures, it is necessary to provide heating of the leachate to maintain a temperature of at least 20°C. Heating can be accomplished by recirculating a portion of the leachate and microorganisms from the SBR reactor through a heat exchanger, through which hot liquid produced by a boiler is recirculated. The boiler can be fuelled by landfill gas, or alternately by natural gas, propane, other fuels or heat sources (i.e. waste heat).

Total nitrogen removal can also be accomplished by the SBR process, if necessary, by adding an anoxic (without oxygen) treatment stage to the sequence. During this stage, denitrifying microorganisms convert the oxidized nitrogen compounds to nitrogen and oxygen gas.

SBR treatment of leachate usually requires chemical addition of phosphorus to satisfy microbial nutrient requirements, and polymer to assist in settling of the biomass. Alkalinity may also need to be added at times to support the nitrification process if inadequate alkalinity is available in the leachate.

In addition to removing most of the COD, BOD and nitrogen compounds, the aerobic biological treatment will remove most of the individual organic compounds present in the leachate. In addition, some removal of metals will occur through adsorption to the biomass which is ultimately removed from the system for disposal. Some of the COD is comprised of compounds which may be recalcitrant to biological treatment and it is expected that some concentration of COD will remain in the aerobic biological reactor effluent.

The SBR system tanks have passive exhaust vents. Odours from the biological activity in the tanks may be periodically released from the vents and are typically directed to an activated carbon adsorption system to manage any potential odours.

2.4.3 Chemical Treatment

Chemical treatment will be required if concentrations of metals in excess of discharge requirements remain after biological treatment. If necessary, chemicals would be added to pretreated leachate in one or more tanks containing mixers to accomplish precipitation of metal salts. Chemical additives including sodium hydroxide, lime, or other caustic or corrosive chemicals could be used to increase the pH of the leachate and cause precipitation of metal



hydroxides. Other metal salts such as ferric chloride and organic-based polymers could be used in the process to enhance floc formation and metals removal.

2.4.4 Filtration

After chemical treatment, filtration is required to remove precipitated metal salts from the treated leachate. Filtration can be accomplished via granular media filters, cloth media filters, or low pressure membrane filtration. Each form of filtration includes media through which the treated leachate passes; the media allows the liquid to pass through, but retains much or all of the precipitated solids. Depending on the type of filtration, solids which build up in the media over time are periodically removed by backwashing, and the backwash waste may require further treatment prior to disposal.

2.4.5 Reverse Osmosis

Reverse osmosis is a membrane filtration technology used to remove dissolved inorganic compounds, as well as larger organic molecules. This technology involves passing the treated, filtered leachate through reverse osmosis membranes at relatively high pressure. Treated leachate flows through the membranes under pressure, while dissolved salts are retained. The dissolved salts are removed from the process as reject water, and this stream can constitute a relatively high-volume waste stream that may require further treatment.

2.4.6 Granular Activated Carbon Adsorption

Granular activated carbon adsorption is a filtration process that utilizes granular activated carbon contained in filter vessels. Treated leachate would be passed through the beds of carbon, and organic compounds remaining in the leachate would be retained by the carbon through adsorption. The organic compounds build up in the carbon after a period of time, and when the adsorptive capacity of the carbon is reached, it must be replaced and the spent carbon must be either re-activated or disposed. This process would be required only if remaining concentrations of compounds contributing to recalcitrant COD must be removed. Other technologies, such as catalyzed chemical oxidation, may also provide the necessary degree of treatment, and the final technology selection would be made based on an assessment of the organic compounds to be removed and an analysis to determine the most effective means.



3. Description of Leachate Treatment Alternatives

A range of alternatives for managing leachate disposal are potentially available. The following provides a brief description of the five leachate treatment alternatives for disposal of leachate identified by WM for assessment as part of the EA. WM has operating experience with these five alternatives and has operated them effectively at other landfill sites across North America for the disposal of leachate. A more detailed description of each alternative including a process schematic of the alternative along with feasibility and reliability, regulatory, environmental and cost considerations, are presented in the following subsections.

1. **On-site Tree Irrigation**

This alternative would involve irrigation of trees (typically poplar and/or willow) in order to dispose of the leachate. This alternative may require partial or full on-site treatment using chemical and/or biological processes to treat the leachate prior to irrigation. The treated leachate will be stored in a pond and then discharged to a tree plantation during days with suitable weather conditions. No liquid effluent would leave the WCEC site.

2. **On-site Leachate Evaporation**

This alternative would involve use of evaporator technology to dispose of leachate. Leachate from the landfill would be pumped to an equalization tank that will provide storage to handle peaks in leachate generation. The leachate would then be fed to the evaporator for processing. The evaporator system may utilize landfill gas as the energy source to evaporate the leachate or waste heat from the landfill gas co-generation facility. Depending upon the strength of the leachate and the resulting air quality emissions, the leachate may have to be pretreated using a chemical and/or biological process prior to evaporation. These units have been widely used in the U.S. for a number of years for leachate disposal.

3. **Off-site Effluent Discharge to Surface Water**

This alternative would involve disposal of fully treated leachate by discharging it to a nearby surface watercourse. Collected leachate would be treated on-site using chemical and/or biological processes to meet Ontario Provincial Water Quality Objectives (PWQO) followed by storage of the treated effluent. The stored effluent would then be discharged to a surface watercourse. The nearest surface watercourse is the southern branch of the Huntley Creek which drains to the Carp River. PWQO are surface water quality criteria established by the Province of Ontario to protect aquatic life and recreational water users.

4. **Off-site Effluent Discharge to City of Ottawa Sanitary Sewer**

This alternative would involve disposal of leachate to the City of Ottawa sanitary sewer system. The collected leachate may require pretreatment on-site using either chemical



and/or biological processes in order to meet the City's sewer use bylaw. The leachate effluent would then be discharged to an existing forcemain at Carp Road and Highway 417. The effluent would be further treated at the City's Robert O. Pickard Environmental Centre (ROPEC) facility.

5. Truck Haulage Off-site to Alternative Wastewater Treatment Plant

This alternative would involve trucking of the leachate to one or more wastewater treatment plants outside Ottawa for disposal. The collected leachate may require pretreatment using chemical and/or biological processes if required to meet the quality parameters of the receiving wastewater treatment plant(s).

3.1 On-site Tree Irrigation

This alternative relies on trees (typically poplars and/or willows) to uptake leachate to satisfy the plants' requirements for moisture and nutrients, and thereby eliminates any off-site discharge of leachate for disposal. Since the growth season of the trees is limited to certain times of the year (May to October), storage of leachate will be required during non-growing times.

WM utilizes poplar trees for leachate treatment and disposal at other facilities in Ontario. Depending on where the trees are planted (on top of a landfilled area or not) it may be necessary to provide full treatment or some level of pretreatment of the leachate prior to application to the trees to achieve background groundwater concentrations. Assuming the trees are not planted on waste at the WCEC, biological treatment and physical/chemical treatment for metals removal would be required to achieve the standards for groundwater discharge. The biological treatment system would include equalization followed by activated sludge treatment using a sequencing batch reactor for removal of organic and nitrogen compounds. Some removal of metals may be achieved via oxidation and adsorption in the sequencing batch reactor process. Residual metals could be removed via chemical treatment and filtration using granular media or low pressure membrane filtration. These processes were described earlier in Section 2.4.

Typically the application rate for leachate to a tree plantation is determined based on the micronutrient chemical parameters of the treated leachate. An adequate planting area is required to allow for irrigation of all of the leachate that is generated during the year. For trees, the area is dictated by the expected annual uptake of leachate during the growing season. The area required for the trees is estimated to be approximately 8 hectares for the projected maximum annual average leachate generation rate. Calculations to determine the approximate area required for uptake of leachate by poplar trees are included in **Appendix A**.

For the purposes of this assessment, it is assumed that six months of storage volume would be required to store pretreated leachate during weather conditions (i.e. non-growing season) that



would prevent the application of leachate to the trees. A large storage pond with an approximate volume of 81,000 cubic metres would therefore be required to provide six months of pretreated leachate storage at the approximate maximum annual average leachate generation rate (5.1 L/s). The calculations used to determine the size of the storage pond are included in **Appendix A**.

A schematic of a treatment system utilizing tree irrigation for leachate disposal is provided in **Figure 2**. It should be noted that some of the treatment process steps shown may not be required based on site-specific requirements.

3.1.1 Feasibility and Reliability

This alternative would require a relatively large amount of property for the leachate storage pond and for the trees (i.e. about 8 ha or approximately one quarter the area of the preferred landfill footprint) to be irrigated. The treed area required could be developed as a single area or multiple areas both on-site and /or off-site pending final design of new landfill footprint. This will be identified in the Detailed Impact Assessment section of the EA.

If treatment of the leachate is required for removal of organics and metals prior to irrigation, the treatment system will be relatively complex and require implementation of chemical and/or biological processes.

The winter storage requirements make this alternative unreliable as a single approach to meet the ongoing leachate disposal requirements in a consistent manner.

3.1.2 Regulatory Considerations

Approval, as part of the landfill Environmental Compliance Approval (ECA), will be required to allow irrigation of trees. An ECA (Air) may also be required for a typical pretreatment process, if necessary. In the event that the tree plantation is located off-site, the receiving site is expected to require additional approval from the MOE.

3.1.3 Environmental Considerations

Leachate will be treated prior to irrigation and the application rate will be controlled to ensure that over irrigation of plantation or run-off to surface water does not occur. There may be a need to remove existing vegetation to accommodate the new plantation. Visual screening of the site may be provided by the plantation. On-site truck movements related to management of residuals may result in some limited dust, combustion and noise emissions.



3.1.4 Capital and Operating Costs

The capital cost of this alternative is expected to be relatively high, due to the large property requirement associated with the leachate storage pond and area for tree irrigation, as well as the relatively complex level of treatment that may be required prior to irrigation. If basic biological treatment is required, the operational and maintenance cost will be modest, but if a high degree of treatment is required, including physical/chemical treatment for metals removal, the operational and maintenance cost will be relatively high due to chemical, energy, and equipment maintenance costs.

3.2 On-site Leachate Evaporation

Under this alternative, collected leachate would be stored to provide equalization of peak day flows, and then treated with on-site evaporation equipment to reduce the leachate volume to a small amount of residual solids that could be disposed in the landfill, or hauled off-site for disposal. Leachate storage would be provided by an above-grade, steel tank constructed within a containment area which will also minimize any odours from the untreated leachate. Typically, storage volumes are provided to contain two to five days of average leachate production, which could range up to 2,200 cubic metres for the estimated maximum annual average leachate generation rate.

Pretreatment of the leachate may be required prior to the evaporation process. The requirement for pretreatment is dependent on the concentration of various chemical parameters which may damage the evaporator equipment or create air emission standards exceedances including odours. The types of biological and/or chemical treatment technologies that may be required were described earlier in section 2.4.

Various forms of leachate evaporators are available on the market. Simple evaporator systems utilize direct injection of combustion gases into an evaporator vessel containing leachate. The resulting vapours may be directly discharged to the atmosphere, or may require further treatment via thermal oxidation to reduce concentrations of volatile organic compounds, if necessary, to meet air emission regulatory requirements. Emissions are dependent upon the specific leachate characteristics. Estimates of mass annual emissions are provided in **Table 3** for the prevalent volatile organic compounds present in the leachate. These estimates assume no pretreatment of leachate is undertaken.

Residual dissolved solids in a small amount of water remain after evaporation, and typically are continuously withdrawn from the evaporation system to prevent excessive build-up and potential fouling of the evaporator surfaces. A clarifier can be used to provide further separation of the



solids, and the overflow from the clarifier is returned to the evaporator for treatment. The quantity of residual solids is dependent on the leachate characteristics, but is typically approximately 3 to 5 percent of the initial leachate volume, or about 13 to 22 cubic metres per day. The solids could be disposed in the landfill, or could be hauled off-site for disposal.

Table 3. Estimated Air Emissions*, On-Site Evaporator Treatment

Parameter	Units	Estimated Emissions
Benzene	kg/yr	0.965
Chlorobenzene	kg/yr	1.126
1,4-Dichlorobenzene	kg/yr	3.538
cis-1,2-Dichloroethylene	kg/yr	0.965
Ethylbenzene	kg/yr	6.433
Toluene	kg/yr	19.300
1,3,5-Trimethylbenzene	kg/yr	1.126
p+m-Xylene	kg/yr	14.475
o-Xylene	kg/yr	6.433
Xylene	kg/yr	20.908

*Note: * based on data from January 2010 Comprehensive Analysis*

If available, landfill gas may be used to heat the leachate. If landfill gas is not available, or is available in insufficient quantities, the heating fuel can be supplemented with natural gas, propane, or other fuels. Since leachate is comprised primarily of water, the energy requirement associated with evaporating leachate is very high compared to other treatment alternatives.

A schematic of a typical leachate evaporator system is provided in **Figure 3**.

3.2.1 Feasibility and Reliability

Many forms of evaporators are available and provide reliable treatment. Due to the high-temperature operation and matrix of typical leachates, frequent maintenance and/or replacement of the evaporator equipment may be necessary. Leachate typically contains relatively high concentrations of salts, which contribute to a corrosive environment exacerbated by the presence of high temperatures. Leachate also typically contains high concentrations of other dissolved solids such as calcium and magnesium which, when concentrated in the evaporator, can contribute to scaling of the evaporator surfaces and may decrease the equipment's effectiveness and require cleaning.

The evaporator system has a relatively small footprint, and should be relatively simple to site at the facility. Proximity to the source of landfill gas, if available, is an important consideration to



reduce the amount of gas pipeline required to reach the evaporator system. The evaporator will have a visible combustion stack and vapour plume and should be located on-site to minimize visual impact.

3.2.2 Regulatory Considerations

Heating of the leachate will result in the formation of water vapour, as well as volatilization of some organic constituents contained in the leachate. An ECA (Air) will be required for the air emissions from the evaporator system and potentially the pretreatment process, if required. Treatment of the evaporation emissions utilizing technology such as thermal oxidation or adsorption may be required to meet air emissions discharge limits.

3.2.3 Environmental Considerations

Evaporation of untreated leachate may have some potential for low concentration emissions of volatile organic compounds and odours. These emissions will be discharged via a visible stack with a steam plume. There will be no discharges to groundwater or surface water. On-site truck movements related to management of residuals may result in some limited dust, combustion and noise emissions.

3.2.4 Capital and Operating Costs

The evaporator system is complex, and the up-front cost is relatively high. Capital costs will increase based on the need for any pretreatment or air emissions treatment systems. If landfill gas is available as a fuel source, the operating cost can be relatively low; however, the lost value of the landfill gas for other sources of energy production must also be considered. If other fuel sources must be used, the energy cost associated with leachate evaporation is very high. Typical operation and maintenance labour costs are expected to be relatively moderate, but may increase if maintenance problems with corrosivity and/or scaling occur or if pretreatment of leachate is required.

3.3 Off-site Effluent Discharge to Surface Water

This alternative relies on having access to a surface watercourse suitable for receiving fully treated leachate. Effectively, the treated leachate is disposed in the watercourse with no further treatment. Potential surface water discharge locations for treated leachate, in proximity to the WCEC, include the Huntley Creek or Carp River. The southern branch of the Huntley Creek (or the South Huntley Creek) would be closest in proximity to the discharge point from the site (i.e. minimum of 500 metres depending on the location of the discharge point), with the Huntley



Creek and Carp River farther downstream (see **Figure 1**). The leachate may need to be fully treated on-site in order to meet the PWQO. The treated leachate could then be discharged to the roadside ditch along Carp Road, which drains to the South Huntley Creek. However, the ditch conditions vary throughout the year and include extended periods of no or low flow to frozen in the winter and would not have any assimilative capacity during substantial portions of the year. The treated leachate would have to be stored on-site and then discharged at appropriate times of the year to optimise any assimilative capacity of the receiving waters. Similar to the tree irrigation alternative, pond storage for as much as 81,000 cubic metres of pretreated leachate may be necessary.

Alternatively, the treated leachate could be pumped via a new forcemain to the selected receiving water body for discharge. The assimilative capacity of the potential receiving water bodies would need to be established to confirm that treated leachate could be discharged without environmental harm. Supporting documentation for the Carp River restoration project (*Post-Development Flow and Characteristics and Flood Level Analysis for Carp River, Feedmill Creek and Poole Creek* – CH2MHill 2006) notes that there are extensive periods during the summer when flows at surface water locations along Richardson Side Road and Huntmar Drive are minimal, and there is no sustained baseflow. Monitoring performed by AECOM in 2006 documented flows in South Huntley Creek at two locations near the intersection of Carp Road and Richardson Side Road ranging from 1 to 114 L/s, and 12 to 109 L/s, respectively. Additional monitoring in 2011 has identified extended periods during which there is no flow in South Huntley Creek. This no flow condition is consistent with other observations made in the area with the Rideau Valley Conservation Authority declaring a low water condition in their watershed and noting that the water level in the Ottawa River is presently close to the lowest recorded since 1950. At the projected typical maximum annual average leachate flow rate of 5.1 L/s, the leachate discharge could account for all, or a significant portion of the flow in the South Huntley Creek. It is therefore expected that the assimilative capacity of South Huntley Creek will be limited or non-existent.

Water quality monitoring performed for the South Huntley Creek, in 2006, indicated that PWQO were not met within the creek for several parameters including Total Phosphorus, Iron and Ammonia. Insufficient flow in South Huntley Creek in 2011 prevented the collection of water quality data for the majority of the year. Data was available in late September and October and monitoring results showed water quality in South Huntley Creek varying from poor to moderate. Based on the relatively low flow of water through the South Huntley Creek as well as the identified water quality issues, it is expected that a very high level of treatment will be required to achieve water quality standards for off-site discharge. It is also possible that discharge may not be permitted at all given that water quality standards have historically not been met in the watercourse.



The nearest receiving watercourse with potential for sufficient permanent flow would be the Carp River, downstream of its confluence with Huntley Creek, approximately 5 kilometres from the proposed new landfill footprint.

The high degree of treatment will require a combination of biological and physical/chemical processes. The process train required to fully treat the leachate to support discharge of effluent off-site to a surface watercourse is expected to include all of the steps identified in section 2.4.

A schematic of a leachate treatment system that may be suitable for off-site discharge to surface water is provided in **Figure 4**.

3.3.1 Feasibility and Reliability

The leachate treatment processes required to discharge to a local surface watercourse represents a highly complex system that will require a high level of operator attention and maintenance. The technologies are well-proven for treating wastewater and reliable in achieving water quality requirements, given proper operation. However, due to the unique and changing characteristics of landfill leachate, and the very limited assimilative capacity of the potential downstream receiving watercourses, the reliability of this alternative is uncertain. Due to the need to meet PWQO for discharge and the almost non-existent assimilative flow in the Carp Road ditch, treated leachate would need to be conveyed by forcemain to the nearest appropriate receiving watercourse, which is the Carp River, located approximately 5 kilometres away. WM's inability to construct a forcemain of this distance, involving numerous properties which they do not own, and the uncertainty of obtaining the required approvals (e.g., MOE, MNR, MVCA), make this alternative largely unfeasible.

Due to the number of treatment processes that may need to be combined to achieve PWQO standards prior to discharge and the storage of treated leachate, the space requirement for this alternative is expected to be moderately larger in comparison to most of the other leachate treatment alternatives.

3.3.2 Regulatory Considerations

An *Ontario Water Resources Act* ECA will be required for discharge of the treated leachate to the potential receiving surface watercourse. It is expected that very stringent discharge requirements will be required due to the expected low assimilative capacity and existing water quality in the potential candidate receiving water bodies. An ECA (Air) may also be required depending on the on-site treatment process.



3.3.3 Environmental Considerations

Leachate will require full treatment prior to being discharged off-site to surface water. The closest potential receiving watercourses may include man-made (i.e., Carp Road ditch) or natural (i.e., South Huntley Creek) systems. These systems typically have no flow or very low flow in areas in close proximity to the site. On-site truck movements related to management of residuals may result in some limited dust, combustion and noise emissions.

3.3.4 Capital and Operating Costs

Both the capital and operating costs for this leachate alternative are expected to be relatively high, as a result of the large number of treatment processes and associated energy, chemical, maintenance and testing, possible waste disposal requirements, and potential requirement for a forcemain.

3.4 Off-site Effluent Discharge to City of Ottawa Sanitary Sewer

Off-site discharge of leachate to the City of Ottawa sanitary sewer is the method currently being used for disposing leachate from the existing Ottawa WMF. Under this alternative, equalization would be provided to buffer the low and high leachate flows, from the new landfill footprint, that are experienced on a daily and seasonal basis. As described in the alternatives above, it is typical to provide two to five days of storage for the average projected leachate flow, which would result in a volume of up to 2,200 cubic metres.

Leachate would be pretreated with aerobic biological treatment utilizing a SBR reactor to remove concentrations of COD, BOD, and ammonia-nitrogen and comply with City of Ottawa sanitary sewer discharge requirements. Air emissions from the pretreatment process tanks are typically directed to an activated carbon adsorption system. The SBR technology is described earlier in section 2.4. Pretreated leachate would be discharged to the existing forcemain at Carp Road and Highway 417 (see **Figure 1**) for further treatment at the City's ROPEC facility. The ROPEC facility was built in 1962 as a primary wastewater treatment facility and subsequently upgraded to include a secondary treatment process and biosolids processing. The ROPEC is licensed to operate by the MOE. The City of Ottawa reports that ROPEC meets all provincial guidelines for wastewater effluent as defined by the MOE. The receiving water body for the ROPEC facility is the Ottawa River. The facility has capacity to treat an average of 545 million liters of wastewater per day. The approximate maximum leachate generation rate is estimated to be 5.1 l/s or 440,640 l/day. This is less than 0.08% of the ROPEC capacity.



The projected capacity of the SBR reactor required for the new landfill footprint would have an anticipated volume of up to approximately 2,750 cubic metres, if based on the estimated maximum annual average leachate generation rate. It will be necessary to provide tankage for equalization and storage of waste biomass, as well as boiler/heat exchanger capacity.

A schematic of a pretreatment system suitable for treatment of leachate to comply with sanitary sewer discharge requirements is provided in **Figure 5**.

3.4.1 Feasibility and Reliability

Aerobic biological treatment of leachate via SBR technology is well-proven and reliable, and has been used by WM at numerous other landfill sites. The automated technology allows for process adjustments to be made in response to changing leachate characteristics and/or discharge requirements, and minimizes the need for operator attention and intervention. Waste biomass generated by treatment can typically be disposed of in the landfill or off-site.

After pretreatment, the leachate characteristics are similar to those of domestic wastewater and will meet the City's Sewer Use By-law. The City's ROPEC facility has significant treatment capacity in comparison to the expected load from the WCEC pretreated leachate, and therefore the leachate is expected to have minimal impact to the municipal wastewater treatment facility.

3.4.2 Regulatory Considerations

Pretreatment of leachate with sanitary sewer discharge will require the approval of, and an agreement with, the City of Ottawa. The discharge will need to comply with the City's Sewer Use By-Law. An ECA (Air) will also be required for the pretreatment process.

3.4.3 Environmental Considerations

Leachate will be pretreated prior to direct discharge to the sanitary sewer with no potential for contact with groundwater or surface water. The treated leachate will meet sewer use requirements and not affect surface water quality. On-site truck movements related to management of residuals may result in some limited dust, combustion and noise emissions.

3.4.4 Capital and Operating Costs

The capital and operating costs of this alternative are expected to be moderate, and lower than the capital and operating costs of most of the other alternatives under consideration. The cost



for discharge of the pretreated leachate to the City of Ottawa's sanitary sewer system is a component of the operating costs.

3.5 Truck Haulage Off-site to Alternative Wastewater Treatment Plant

This alternative would involve storing the collected leachate and then hauling it to one or more alternative wastewater treatment plants, other than the City of Ottawa's ROPEC facility. The available capacity of one or more wastewater treatment plants to accept the leachate would need to be determined, and approval for the hauled discharge(s) would need to be sought. Depending on the receiving wastewater treatment plant, the leachate may or may not require pretreatment. If pretreatment is required, this alternative would likely involve the same leachate pretreatment system as described in section 2.4, depending on the specific requirements of the receiving wastewater treatment plant.

Leachate would need to be stored on-site to provide capacity for days when trucks are unable to haul, or in the event the wastewater treatment plant(s) is unable to accept leachate. In addition, storage may need to be constructed at the wastewater treatment plant location(s) to allow for consistent dosing of the leachate to the treatment facility. The availability of leachate storage at the treatment plant site is critical in the scenario where it receives untreated leachate, as consistent dosing of untreated leachate is important to avoid treatment plant upsets.

It is expected that approximately 15 truckloads of leachate (30 cubic metres each) may need to be hauled daily, based on the projected maximum annual average leachate generation rate.

A schematic of a leachate pretreatment system for hauling of pretreated leachate to off-site wastewater treatment facilities for disposal is provided in **Figure 6**.

3.5.1 Feasibility and Reliability

As described previously, SBR treatment of leachate is well-proven and reliable in achieving discharge standards required by most municipal wastewater treatment authorities. Hauling of leachate is a common industry practice and is reliant on availability of suitable trucking equipment and drivers, and with the potential to be impacted slightly by adverse weather conditions.

The reliability of this alternative is also influenced by the capacity and operation of the wastewater treatment plant(s) to which the leachate is hauled and discharged. Smaller wastewater treatment facilities may experience load restrictions and/or process upsets which





may prevent the discharge of leachate at the generated volumes and during certain periods of time. WM may need to rely on more than one wastewater treatment plant to manage the volumes of leachate generated to ensure the reliability of this alternative.

3.5.2 Regulatory Considerations

Pretreatment of leachate with hauling and discharge to one or more wastewater treatment facilities will require the approval of, and a permit from, municipal wastewater authorities to which the leachate will be discharged, and proper manifesting of hauled loads. An ECA (Air) may also be required for the pretreatment process.

3.5.3 Environmental Considerations

Leachate will be pretreated prior to truck haulage off-site to meet the receiver's facility requirements and not affect surface water quality. There is no potential for contact with groundwater or surface water. On-site truck movements related to management of residuals may result in some limited dust, combustion and noise emissions. The requirement for approximately 15 tanker trucks per day entering the site and then leaving loaded may affect traffic on Carp Road.

3.5.4 Capital and Operating Costs

Costs associated with this alternative include the cost for hauling of leachate to one or more wastewater treatment facilities, as well as the cost for disposal of the leachate at the facilities. The capital and operating costs associated with leachate pretreatment, if required as described under this alternative, are expected to be moderate. The hauling cost can be significant, and may be higher than the cost for pretreatment, if needed, depending upon the distance which the leachate must be transported.



4. Evaluation of Leachate Treatment Alternatives

This section describes the evaluation methodology used to compare the leachate treatment alternatives to one another. It details results of the comparative evaluation, including a rationale for ranking of alternatives, and identifies a preferred leachate treatment alternative for the disposal of leachate.

As indicated previously, at this stage the leachate treatment alternatives have been described to a conceptual level of detail, focused primarily on the characteristics used to differentiate the alternatives from one another in order to facilitate the comparative analysis. The preferred leachate treatment alternative will be described in further detail as part of the detailed impact assessment of the undertaking.

4.1 Evaluation Methodology

The comparative evaluation of leachate treatment alternatives was completed using a “Reasoned Argument” or “Trade-off” method, as provided for in the approved ToR. This method is based on the following two activities:

1. Identify the predicted level of effect (‘No Net Effect’, ‘Low Net Effect’, ‘Moderate Net Effect’ or ‘High Net Effect’) associated with each alternative for each indicator; and,
2. Rank each alternative from most preferred to least preferred based on the predicted level of effect at the criteria and environmental component level in order to determine an overall ranking for each alternative.

Criteria and indicators under the following environmental components were selected in order to comparatively evaluate the leachate treatment alternatives (see **Table 4** for a full list of criteria):

- Atmospheric Environment
- Geology and Hydrogeology
- Surface Water Resources
- Biology
- Transportation
- Land Use
- Social
- Site Design and Operations



The proposed evaluation criteria and indicators were presented at Open House #3 for public comment. The proposed evaluation criteria and indicators, and evaluation methodology were also presented and discussed during workshop #3. Based on the evaluation criteria and indicators, the net effect(s) resulting from the implementation of each of the five leachate treatment alternatives were predicted at the indicator level, with the assumption that appropriate mitigation measures would be put in place. The net effects were then used to compare the leachate treatment alternatives to one another. The results of this comparison are detailed in **Table 4**.

4.2 Evaluation Results

The results of the net effects evaluation of the leachate treatment alternatives in **Table 4** below are summarized for each individual leachate treatment alternative in the following subsections. In this evaluation, the implementation of each leachate treatment alternative was considered in a stand-alone capacity.

4.2.1 Option #1 – On-site Tree Irrigation

The implementation of Option #1 – On-site Tree Irrigation would result in no to low net effects with respect to odour, air quality, noise, groundwater, surface water, aquatic environment, transportation, and land use. There would be a slight positive net effect in terms of the terrestrial and visual environments, as the planting of trees would potentially increase the amount of vegetation within the study area, and thus the available wildlife habitat, and would also partially obscure the view of the landfill.

There is a relatively high capital cost and a moderate to high operating cost associated with the implementation of this leachate treatment alternative. If implemented, approximately 8 hectares of land would be required for the tree plantation in order to accommodate the rate of leachate production from the landfill. As the growing season for trees is limited to certain times of the year (May to October), storage of leachate would be required during winter months, decreasing overall reliability of this approach. The capacity to store leachate during freezing conditions or other weather conditions that would prevent the application of leachate to the trees (approximately six months of the year) would therefore be required for this alternative and could be achieved via a storage pond with an approximate storage volume of up to 81,000 cubic metres.



Table 4. Comparative Evaluation of Leachate Treatment Alternatives

Environmental Component	Criteria	Indicators	Leachate Treatment Alternatives				
			Option #1 – On-site Tree Irrigation	Option #2 – On-site Leachate Evaporation	Option #3 – Off-site Effluent Discharge to Surface Water	Option #4 – Off-site Effluent Discharge to City of Ottawa Sanitary Sewer	Option #5 – Truck Haulage Off-site to Alternative Wastewater Treatment Plant
			Net Effects	Net Effects	Net Effects	Net Effects	Net Effects
Atmospheric Environment	Odour	<ul style="list-style-type: none"> Predicted odour emissions. 	None as leachate storage pond contains only treated leachate.	None as there is no open storage of leachate. None as leachate is either pretreated prior to evaporation or evaporated emissions are treated to meet discharge limits.	None as leachate storage pond contains only treated leachate.	None as there is no open storage of leachate.	None as there is no open storage of leachate.
			NO NET EFFECTS	NO NET EFFECTS	NO NET EFFECTS	NO NET EFFECTS	NO NET EFFECTS
		<ul style="list-style-type: none"> Number of off-site receptors potentially affected (residential properties, public facilities, businesses and institutions). 	No off-site effects predicted.	No off-site effects predicted.	No off-site effects predicted.	No off-site effects predicted.	No off-site effects predicted.
			NO NET EFFECTS	NO NET EFFECTS	NO NET EFFECTS	NO NET EFFECTS	NO NET EFFECTS
		Criteria Ranking:	Tied for 1st	Tied for 1st	Tied for 1st	Tied for 1st	Tied for 1st
		Criteria Rationale	All options are preferred as there are no net effects predicted for odour emissions.				
	Air Quality	<ul style="list-style-type: none"> Predicted air emissions. 	Emissions from leachate pretreatment process that would require ECA (Air).	Emissions from leachate pretreatment process that would require ECA (Air). Emissions from evaporation process that would require ECA (Air).	Emissions from leachate pretreatment process that would require ECA (Air).	Emissions from leachate pretreatment process that would require ECA (Air).	Emissions from leachate pretreatment process that would require ECA (Air).
			LOW NET EFFECTS	LOW NET EFFECTS	LOW NET EFFECTS	LOW NET EFFECTS	LOW NET EFFECTS
		<ul style="list-style-type: none"> Number of off-site receptors potentially affected (residential properties, public facilities, businesses, and institutions). 	No off-site effects predicted.	No off-site effects predicted.	No off-site effects predicted.	No off-site effects predicted.	No off-site effects predicted.
			NO NET EFFECTS	NO NET EFFECTS	NO NET EFFECTS	NO NET EFFECTS	NO NET EFFECTS
		Criteria Ranking:	Tied for 1st	2nd	Tied for 1st	Tied for 1st	Tied for 1st
		Criteria Rationale	Options 1, 3, 4, and 5 are most preferred as there are no to low net effects predicted for air emissions. Option 2 also has no to low predicted net effects; however, ranks 2nd because this leachate treatment process includes two sources of emissions (pretreatment and evaporation).				
<ul style="list-style-type: none"> Predicted dust emissions. 	Emissions from haulage of residual sludge from leachate treatment facility to the landfill for disposal (on-site).	Emissions from haulage of residual sludge from leachate treatment facility to the landfill for disposal (on-site).	Emissions from haulage of residual sludge from leachate treatment facility to the landfill for disposal (on-site).	Emissions from haulage of residual sludge from leachate treatment facility to the landfill for disposal (on-site).	Emissions from haulage of residual sludge from leachate treatment facility to the landfill for disposal (on-site).	Emissions from haulage of residual sludge from leachate treatment facility to the landfill for disposal (on-site) as well as from haulage of pre-treated leachate to a wastewater treatment plant (off-site).	
	LOW NET EFFECTS	LOW NET EFFECTS	LOW NET EFFECTS	LOW NET EFFECTS	LOW NET EFFECTS	MODERATE NET EFFECTS	
<ul style="list-style-type: none"> Number of off-site receptors potentially affected (residential properties, public facilities, businesses, and institutions). 	No off-site effects predicted.	No off-site effects predicted.	No off-site effects predicted.	No off-site effects predicted.	No off-site effects predicted.	Potential to affect off-site receptors.	
	NO NET EFFECTS	NO NET EFFECTS	NO NET EFFECTS	NO NET EFFECTS	NO NET EFFECTS	LOW NET EFFECTS	
	Criteria Ranking:	Tied for 1st	Tied for 1st	Tied for 1st	Tied for 1st	2nd	
	Criteria Rationale	Options 1, 2, 3, and 4 are most preferred as there are no or low net effects predicted for dust emissions.					

Table 4. Comparative Evaluation of Leachate Treatment Alternatives

Environmental Component	Criteria	Indicators	Leachate Treatment Alternatives					
			Option #1 – On-site Tree Irrigation	Option #2 – On-site Leachate Evaporation	Option #3 – Off-site Effluent Discharge to Surface Water	Option #4 – Off-site Effluent Discharge to City of Ottawa Sanitary Sewer	Option #5 – Truck Haulage Off-site to Alternative Wastewater Treatment Plant	
			Net Effects	Net Effects	Net Effects	Net Effects	Net Effects	
	<ul style="list-style-type: none"> Predicted combustion emissions. Number of off-site receptors potentially affected (residential properties, public facilities, businesses, and institutions). 	<ul style="list-style-type: none"> Predicted combustion emissions. 	Emissions from haulage of residual sludge from leachate treatment facility to the landfill for disposal (on-site).	Emissions from haulage of residual sludge from leachate treatment facility to the landfill for disposal (on-site).	Emissions from haulage of residual sludge from leachate treatment facility to the landfill for disposal (on-site).	Emissions from haulage of residual sludge from leachate treatment facility to the landfill for disposal (on-site).	Emissions from haulage of residual sludge from leachate treatment facility to the landfill for disposal (on-site) as well as from haulage of pre-treated leachate to a wastewater treatment plant (off-site).	
		<ul style="list-style-type: none"> Number of off-site receptors potentially affected (residential properties, public facilities, businesses, and institutions). 	No off-site effects predicted.	No off-site effects predicted.	No off-site effects predicted.	No off-site effects predicted.	Potential to affect off-site receptors.	
		Criteria Ranking:	Tied for 1 st	Tied for 1 st	Tied for 1 st	Tied for 1 st	2 nd	
		Criteria Rationale	Options 1, 2, 3, and 4 are most preferred as there are no or low net effects predicted for combustion emissions.					
	Noise	<ul style="list-style-type: none"> Predicted site-related noise. Number of off-site receptors potentially affected (residential properties, public facilities, businesses, and institutions). 	<ul style="list-style-type: none"> Predicted site-related noise. 	Emissions from haulage of residual sludge from leachate treatment facility to the landfill for disposal (on-site).	Emissions from haulage of residual sludge from leachate treatment facility to the landfill for disposal (on-site).	Emissions from haulage of residual sludge from leachate treatment facility to the landfill for disposal (on-site).	Emissions from haulage of residual sludge from leachate treatment facility to the landfill for disposal (on-site).	Emissions from haulage of residual sludge from leachate treatment facility to the landfill for disposal (on-site) as well as from haulage of pre-treated leachate to a wastewater treatment plant (off-site).
			<ul style="list-style-type: none"> Number of off-site receptors potentially affected (residential properties, public facilities, businesses, and institutions). 	No off-site effects predicted.	No off-site effects predicted.	No off-site effects predicted.	No off-site effects predicted.	Potential to affect off-site receptors.
		Criteria Ranking:	Tied for 1 st	Tied for 1 st	Tied for 1 st	Tied for 1 st	2 nd	
		Criteria Rationale	Options 1, 2, 3, and 4 are most preferred as there are low net effects predicted for noise emissions.					
	Environmental Component Ranking			Tied for 1 st	2 nd	Tied for 1 st	Tied for 1 st	3 rd
	RATIONALE			Options 1, 3, and 4 are ranked first from an Atmospheric component perspective because they have the lowest effects on off-site receptors relating to odour, air, dust, combustion and noise emissions. Option 2 placed in second due to impacts in relation to air emissions, and Option 5 placed in third due to its effects in relation to dust, combustion, and noise emissions.				
Geology & Hydrogeology	Groundwater Quality	<ul style="list-style-type: none"> Predicted effects to groundwater quality at property boundaries and off-site. 	Treated leachate applied to trees not planted on waste.	Equalization tanks enclosed and only treated leachate stored in tank, therefore no contact with groundwater.	Equalization tanks enclosed and only treated leachate stored in pond, therefore no contact with groundwater.	Equalization tanks enclosed and only treated leachate stored in tank, therefore no contact with groundwater.	Equalization tanks enclosed and only treated leachate stored in tank, therefore no contact with groundwater.	
			Equalization tanks enclosed and only treated leachate stored in pond, therefore no contact with groundwater.	NO NET EFFECTS	NO NET EFFECTS	NO NET EFFECTS	NO NET EFFECTS	
			Criteria Ranking:	2 nd	Tied for 1 st	Tied for 1 st	Tied for 1 st	Tied for 1 st
Criteria Rationale			Options 2, 3, 4, and 5 are most preferred as there are no net effects predicted for groundwater quality.					

Table 4. Comparative Evaluation of Leachate Treatment Alternatives

Environmental Component	Criteria	Indicators	Leachate Treatment Alternatives					
			Option #1 – On-site Tree Irrigation	Option #2 – On-site Leachate Evaporation	Option #3 – Off-site Effluent Discharge to Surface Water	Option #4 – Off-site Effluent Discharge to City of Ottawa Sanitary Sewer	Option #5 – Truck Haulage Off-site to Alternative Wastewater Treatment Plant	
			Net Effects	Net Effects	Net Effects	Net Effects	Net Effects	
Groundwater Flow	<ul style="list-style-type: none"> Predicted groundwater flow characteristics. 	<p>No potential leachate contact with groundwater.</p> <p>NO NET EFFECTS</p>	<p>No potential leachate contact with groundwater.</p> <p>NO NET EFFECTS</p>	<p>No potential leachate contact with groundwater.</p> <p>NO NET EFFECTS</p>	<p>No potential leachate contact with groundwater.</p> <p>NO NET EFFECTS</p>	<p>No potential leachate contact with groundwater.</p> <p>NO NET EFFECTS</p>		
		Criteria Ranking:	Tied for 1 st	Tied for 1 st	Tied for 1 st	Tied for 1 st	Tied for 1 st	
		Criteria Rationale	There is no distinction between the options in relation to groundwater flow. All options rank the same.					
		Environmental Component Ranking	2 nd	Tied for 1 st	Tied for 1 st	Tied for 1 st	Tied for 1 st	
RATIONALE			Options 2, 3, 4, and 5 are ranked first from a Geology and Hydrogeology perspective because they have no effect on groundwater quality or flow. Option 1 has a low net effect in relation to groundwater quality as treated leachate will be applied to trees for irrigation.					
Surface Water Resources	Surface Water Quality	<ul style="list-style-type: none"> Predicted effects on surface water quality on-site and off-site. 	<p>Leachate treated prior to irrigation, therefore no potential leachate contact with surface water.</p> <p>LOW NET EFFECTS</p>	<p>No potential leachate contact with surface water.</p> <p>NO NET EFFECTS</p>	<p>Ontario Water Resources Act ECA would be required for discharge to receiving watercourse.</p> <p>Assumes assimilative capacity of surface water (i.e., Huntley Creek or Carp River) will be affected by effluent discharge (i.e., quality).</p> <p>MODERATE NET EFFECTS</p>	<p>Leachate pre-treated to Sewer Use Bylaw standards prior to discharge to sewer/sewage treatment plant.</p> <p>NO NET EFFECTS</p>	<p>No potential leachate contact with surface water.</p> <p>NO NET EFFECTS</p>	
			Criteria Ranking:	2 nd	Tied for 1 st	3 rd	Tied for 1 st	Tied for 1 st
			Criteria Rationale	Options 2, 4, and 5 are ranked first as they do not impact surface water quality.				
			Environmental Component Ranking	2 nd	Tied for 1 st	3 rd	Tied for 1 st	Tied for 1 st
Surface Water Quantity	<ul style="list-style-type: none"> Change in drainage areas. Predicted occurrence and degree of off-site effects. 	<p>Assumes construction of leachate storage pond will alter local drainage patterns.</p> <p>LOW NET EFFECTS</p>	<p>No change in drainage areas.</p> <p>NO NET EFFECTS</p>	<p>Assumes construction of leachate storage pond will alter local drainage patterns.</p> <p>LOW NET EFFECTS</p>	<p>No change in drainage areas.</p> <p>NO NET EFFECTS</p>	<p>No change in drainage areas.</p> <p>NO NET EFFECTS</p>		
		<p>No off-site release of leachate.</p> <p>NO NET EFFECTS</p>	<p>No off-site release of leachate.</p> <p>NO NET EFFECTS</p>	<p>Ontario Water Resources Act ECA would be required for discharge to receiving watercourse.</p> <p>Assumes assimilative capacity of surface water (i.e., Huntley Creek or Carp River) will be affected by effluent discharge (i.e., quality).</p> <p>MODERATE NET EFFECTS</p>	<p>No off-site release of leachate.</p> <p>NO NET EFFECTS</p>	<p>No off-site release of leachate.</p> <p>NO NET EFFECTS</p>		
		Criteria Ranking:	2 nd	Tied for 1 st	3 rd	Tied for 1 st	Tied for 1 st	
		Criteria Rationale	Options 2, 4, and 5 are ranked first as they do not impact surface water quantity.					
Environmental Component Ranking	2 nd	Tied for 1 st	3 rd	Tied for 1 st	Tied for 1 st			
RATIONALE			Options 2, 4, and 5 are ranked first from a surface water perspective as they do not impact surface water quality or quantity.					

Table 4. Comparative Evaluation of Leachate Treatment Alternatives

Environmental Component	Criteria	Indicators	Leachate Treatment Alternatives				
			Option #1 – On-site Tree Irrigation	Option #2 – On-site Leachate Evaporation	Option #3 – Off-site Effluent Discharge to Surface Water	Option #4 – Off-site Effluent Discharge to City of Ottawa Sanitary Sewer	Option #5 – Truck Haulage Off-site to Alternative Wastewater Treatment Plant
			Net Effects	Net Effects	Net Effects	Net Effects	Net Effects
Biology (including Terrestrial and Aquatic environment)	Terrestrial Ecosystems	<ul style="list-style-type: none"> Predicted impact on vegetation communities due to project. 	Potential removal of existing vegetation community and replacement with tree plantation. LOW (POSITIVE) NET EFFECTS	No removal of vegetation. NO NET EFFECTS	No removal of vegetation. NO NET EFFECTS	No removal of vegetation. NO NET EFFECTS	No removal of vegetation. NO NET EFFECTS
		<ul style="list-style-type: none"> Predicted impact on wildlife habitat due to project. 	Potential removal of existing vegetation community and replacement with tree plantation. LOW (POSITIVE) NET EFFECTS	No removal of vegetation. NO NET EFFECTS	No removal of vegetation. NO NET EFFECTS	No removal of vegetation. NO NET EFFECTS	No removal of vegetation. NO NET EFFECTS
		<ul style="list-style-type: none"> Predicted impact of project on vegetation and wildlife including rare, threatened or endangered species. 	Pretreatment facilities located near existing landfill infrastructure and tree plantation located on open land adjacent to landfill footprint. LOW NET EFFECTS	Pretreatment facilities located near existing landfill infrastructure. LOW NET EFFECTS	Pretreatment facilities located near existing landfill infrastructure. LOW NET EFFECTS	Pretreatment facilities located near existing landfill infrastructure. LOW NET EFFECTS	Pretreatment facilities located near existing landfill infrastructure. LOW NET EFFECTS
		Criteria Ranking:	1st	Tied for 2nd	Tied for 2nd	Tied for 2nd	Tied for 2nd
		Criteria Rationale	Option 1 ranks first as the planting of trees would have a positive effect on vegetation communities.				
	Aquatic Ecosystems	<ul style="list-style-type: none"> Predicted changes in water quality. 	Leachate treated prior to irrigation, therefore no potential leachate contact with surface water. LOW NET EFFECTS	No potential leachate contact with surface water. NO NET EFFECTS	Assumes assimilative capacity of surface water (i.e., Huntley Creek or Carp River) will be affected by effluent discharge (i.e., quality). MODERATE NET EFFECTS	Leachate pre-treated to sewer Bylaw standards prior to discharge to sewer/sewage treatment plant. NO NET EFFECTS	No potential leachate contact with surface water. NO NET EFFECTS
		<ul style="list-style-type: none"> Predicted impact on aquatic habitat due to project. 	Leachate treated prior to irrigation, therefore no potential leachate contact with surface water. LOW NET EFFECTS	No potential leachate contact with surface water. NO NET EFFECTS	Assumes assimilative capacity of surface water (i.e., Huntley Creek or Carp River) will be affected by effluent discharge (i.e., quality). MODERATE NET EFFECTS	Leachate pre-treated to sewer Bylaw standards prior to discharge to sewer/sewage treatment plant. NO NET EFFECTS	No potential leachate contact with surface water. NO NET EFFECTS
		<ul style="list-style-type: none"> Predicted impact on aquatic biota due to project. 	Leachate treated prior to irrigation, therefore no potential leachate contact with surface water. LOW NET EFFECTS	No potential leachate contact with surface water. NO NET EFFECTS	Assumes assimilative capacity of surface water (i.e., Huntley Creek or Carp River) will be affected by effluent discharge (i.e., quality). MODERATE NET EFFECTS	Leachate pre-treated to sewer Bylaw standards prior to discharge to sewer/sewage treatment plant. NO NET EFFECTS	No potential leachate contact with surface water. NO NET EFFECTS
		Criteria Ranking:	2nd	Tied for 1st	3rd	Tied for 1st	Tied for 1st
		Criteria Rationale	Options 2, 4, and 5 are ranked as first because they do not impact the aquatic ecosystem.				
	Environmental Component Ranking	1st	Tied for 2nd	3rd	Tied for 2nd	Tied for 2nd	
RATIONALE			Option 1 ranks first in relation to Biology as the planting of trees would have a positive impact on vegetation communities and would result in low net effects in relation to the aquatic environment. Options 2, 4, and 5 are tied for second place as they have low or no effect on the terrestrial environment and no impact in relation to the aquatic environment.				

Table 4. Comparative Evaluation of Leachate Treatment Alternatives

Environmental Component	Criteria	Indicators	Leachate Treatment Alternatives				
			Option #1 – On-site Tree Irrigation	Option #2 – On-site Leachate Evaporation	Option #3 – Off-site Effluent Discharge to Surface Water	Option #4 – Off-site Effluent Discharge to City of Ottawa Sanitary Sewer	Option #5 – Truck Haulage Off-site to Alternative Wastewater Treatment Plant
			Net Effects	Net Effects	Net Effects	Net Effects	Net Effects
Transportation	Effects from Truck Transport Along Access Roads	<ul style="list-style-type: none"> Potential for traffic collisions. 	No off-site truck haulage.	No off-site truck haulage.	No off-site truck haulage.	No off-site truck haulage.	Approximately 15 truckloads of pre-treated leachate anticipated daily.
		<ul style="list-style-type: none"> Disturbance to traffic operations. 	No off-site truck haulage.	No off-site truck haulage.	No off-site truck haulage.	No off-site truck haulage.	Approximately 15 truckloads of pre-treated leachate anticipated daily.
	Environmental Component Ranking		Tied for 1 st	Tied for 1 st	Tied for 1 st	Tied for 1 st	2 nd
	RATIONALE			Options 1, 2, 3, and 4 are tied for first from a transportation perspective as they do no impact traffic collisions or operations.			
Land Use	Effects on Current and Planned Future Land Uses	<ul style="list-style-type: none"> Current land use. 	On-site facilities may require site plan approval from the City of Ottawa.	On-site facilities may require site plan approval from the City of Ottawa.	On-site facilities may require site plan approval from the City of Ottawa.	On-site facilities may require site plan approval from the City of Ottawa.	On-site facilities may require site plan approval from the City of Ottawa.
		<ul style="list-style-type: none"> Planned future land use. 	No impact on planned future land use.	No impact on planned future land use.	No impact on planned future land use.	No impact on planned future land use.	No impact on planned future land use.
		Criteria Ranking:	2 nd	Tied for 1 st	Tied for 1 st	Tied for 1 st	Tied for 1 st
		Criteria Rationale	Options 2, 3, 4, and 5 are tied for first as they have low effects in relation to land use and no impact on future land use.				
	Displacement of Agricultural Land	<ul style="list-style-type: none"> Current land use. 	Potential to remove agricultural land.	Pretreatment facilities located near existing landfill infrastructure.	Pretreatment facilities located near existing landfill infrastructure.	Pretreatment facilities located near existing landfill infrastructure.	Pretreatment facilities located near existing landfill infrastructure.
		<ul style="list-style-type: none"> Predicted impacts on surrounding agricultural operations. 	Pretreatment facilities located near existing landfill infrastructure.	Pretreatment facilities located near existing landfill infrastructure.	Pretreatment facilities located near existing landfill infrastructure.	Pretreatment facilities located near existing landfill infrastructure.	Pretreatment facilities located near existing landfill infrastructure.
		Criteria Ranking:	2 nd	Tied for 1 st	Tied for 1 st	Tied for 1 st	Tied for 1 st
		Criteria Rationale	Options 2, 3, 4, and 5 are tied for first as they have no impact on agricultural land.				
Environmental Component Ranking		2 nd	Tied for 1 st	Tied for 1 st	Tied for 1 st	Tied for 1 st	
RATIONALE			Options 2, 3, 4, and 5 are tied for first from a land use perspective, as they have low to no effect in relation to current or future land use and no impact on agricultural land.				
Social	Visual Impact of the Facility	<ul style="list-style-type: none"> Predicted changes in perceptions of landscapes and views. 	Tree plantation may obstruct the view of the landfill.	Pretreatment and facilities near existing landfill infrastructure. Evaporator will include a stack which may be at visible height. There may also be a visible steam plume.	Pretreatment and facilities near existing landfill infrastructure. No noticeable change in current views expected.	Pretreatment and facilities near existing landfill infrastructure. No noticeable change in current views expected.	Pretreatment and facilities near existing landfill infrastructure. No noticeable change in current views expected.
		Environmental Component Ranking	1 st	3 rd	Tied for 2 nd	Tied for 2 nd	Tied for 2 nd
RATIONALE			Option 1 is ranked first as the planting of trees will result in a positive effect on the visual environment.				

Table 4. Comparative Evaluation of Leachate Treatment Alternatives

Environmental Component	Criteria	Indicators	Leachate Treatment Alternatives				
			Option #1 – On-site Tree Irrigation	Option #2 – On-site Leachate Evaporation	Option #3 – Off-site Effluent Discharge to Surface Water	Option #4 – Off-site Effluent Discharge to City of Ottawa Sanitary Sewer	Option #5 – Truck Haulage Off-site to Alternative Wastewater Treatment Plant
			Net Effects	Net Effects	Net Effects	Net Effects	Net Effects
Site Design & Operations	Site Design and Operations Characteristics	• Complexity of site infrastructure.	Relatively high capital cost and moderate to high operating cost.	Relatively high capital and moderate operating costs.	Relatively high capital and high operating costs.	Moderate capital and operating costs.	Moderate capital and high operating costs with trucking.
		• Operational flexibility.	HIGH NET EFFECTS	MODERATE NET EFFECTS	HIGH NET EFFECTS	MODERATE NET EFFECTS	MODERATE NET EFFECTS
	Environmental Component Ranking	LOW NET EFFECTS	LOW NET EFFECTS	LOW NET EFFECTS	LOW NET EFFECTS	LOW NET EFFECTS	
Rationale			Options 2, 4, and 5 are tied for first from a site design and operations perspective, as they have moderate effects in relation to complexity of site infrastructure and low effects in relation to operational flexibility.				
OVERALL RANKING & RATIONALE			Tied for 2 nd	Tied for 2 nd	4 th	1 st	3 rd

4.2.2 Option #2 – On-site Leachate Evaporation

The implementation of Option #2 – On-site Leachate Evaporation would result in no to low net effects with respect to odour, air quality, noise, groundwater, surface water, biology, transportation, and land use.

The implementation of this alternative for the disposal of leachate would result in a moderate effect on the visual environment, as the evaporator would include a visible combustion stack. There is a relatively high capital cost associated with this leachate treatment alternative and relatively moderate operating costs. Due to the high-temperature operation and matrix of typical leachates; however, frequent maintenance and/or replacement of the evaporator equipment may be necessary, which would increase operating costs.

4.2.3 Option #3 – Off-site Effluent Discharge to Surface Water

Implementing Option #3 – Off-site Effluent Discharge to Surface Water would result in low to no net effects in relation to odour, air quality, noise, groundwater, terrestrial environment, transportation, land use, and the visual environment.

The assimilative capacities of both the Carp Road ditch and South Huntley Creek are insufficient to provide a reliable and feasible alternative. Treated leachate would need to be conveyed by forcemain to the nearest appropriate receiving watercourse, which is the Carp River, located approximately 5 kilometres away. As a private proponent, WM would not have the authority to expropriate land or construct private conveyance systems within public right-of-way. This would significantly limit potential for obtaining necessary approvals (e.g., MOE, MNR, MVCA) and make this alternative largely unfeasible. In addition, both the capital and operating costs for this leachate alternative are expected to be relatively high.

4.2.4 Option #4 – Off-site Effluent Discharge to City of Ottawa Sanitary Sewer

Implementation of Option #4 – Off-site Effluent Discharge to City of Ottawa Sanitary Sewer would result in no to low net effects with respect to odour, air quality, noise, groundwater, surface water, biology, transportation, land use, and the visual environment.

There are moderate capital as well as operating costs associated with the implementation of this leachate treatment alternative.



4.2.5 Option #5 – Truck Haulage Off-site to Alternative Wastewater Treatment Plant

Implementation of Option #5 – Truck Haulage Off-site to Alternative Wastewater Treatment Plant would result in no to low net effects in relation to odour, groundwater, surface water, biology, land use, and the visual environment.

Implementation of Option #5 would require approximately 15 truck trips each day (30 cubic metres per truck) of pretreated leachate to one or more off-site wastewater treatment facilities, the locations of which are as yet unknown. This is expected to result in moderate net effects in relation to air quality, noise, and transportation. Moderate capital and high operating costs are associated with the implementation of this leachate treatment alternative.

4.3 Comparative Evaluation of Leachate Treatment Alternatives

4.3.1 Overall Ranking

The ranking of the five stand-alone leachate treatment alternatives resulting from the comparative evaluation, as seen in **Table 4**, indicates that Option #4 – Off-site Effluent Discharge to City of Ottawa Sanitary Sewer is the highest ranked alternative. Option #1 – On-site Tree Irrigation and Option #2 – On-site Leachate Evaporation tied for second, Option #5 – Truck Haulage Off-site to Alternative Wastewater Treatment Plant placed third, and Option #3 – Off-site Effluent Discharge to Surface Water was the lowest ranked.

As described previously, Option #3 is considered to be an unreliable alternative for the disposal of leachate. The assimilative capacities of both the Carp Road ditch and South Huntley Creek are insufficient to provide a reliable and feasible alternative. Treated leachate would need to be conveyed by forcemain to the nearest appropriate receiving watercourse, which is the Carp River, located approximately 5 kilometres away. As a private proponent, WM would not have the authority to expropriate land or construct private conveyance systems within public right-of-way. This would significantly limit potential for obtaining necessary approvals (e.g., MOE, MNR, MVCA) and make this alternative largely unfeasible. In addition, both the capital and operating costs for this leachate alternative are expected to be relatively high. This alternative will not be considered further by WM.

4.3.2 Sensitivity Analysis

Four options remain for consideration as the preferred alternative for leachate treatment. These options were considered both individually and in combination as systems.



4.3.2.1 Individual Alternative Analysis

The potential application of each of the four remaining individual alternative leachate treatment methods require further consideration in terms of their ability to function in a stand-alone capacity. The following describes the opportunities and limitations associated with the implementation of each of these individual options in a stand-alone manner.

Option #1 – On-site Tree Irrigation

Application of this alternative would result in the effective treatment of leachate from the WCEC; however, there are two substantial limitations associated with its implementation as a stand-alone option. The first and most significant limitation is the seasonality associated with leachate treatment by tree irrigation, as irrigation would only be possible from approximately May to October. In order to dispose of leachate by tree irrigation only, six months of storage volume – or up to approximately 81,000 cubic metres – would be required on-site. The second limitation is the area of land required to accommodate a stand of trees sufficiently large enough to handle the total volume of leachate produced by the landfill. As described previously, this would necessitate a tree stand of approximately 8 hectares – or roughly one quarter of the area of the proposed landfill footprint. The required area of land may not be available in the immediate vicinity of the preferred landfill footprint, and additional property may need to be utilized (i.e., west side of William Mooney Road). If insufficient area exists on-site, pre-treated leachate will need to be transferred to an off-site tree plantation area either via pumping and forcemain, or via hauling with trucks. It can therefore be concluded that, although a technically viable leachate treatment alternative, the application of Option #1 in a stand-alone capacity would have significant limitations and would not provide operational flexibility at the WCEC.

Option #2 – On-site Leachate Evaporation

Application of this alternative would result in the effective disposal of leachate at the WCEC. Disposal of pretreated leachate via evaporation would be possible year-round and would require on-site disposal of only 3 to 5 percent of the initial leachate volume in the form of residual solids. Limitations to the implementation of this option include a high capital cost and a moderate impact on the visual environment from the combustion stack and vapour plume. An additional limitation associated with this alternative is that there is, as yet, no precedent for the treatment of leachate via evaporation in Ontario. Despite its viability as a stand-alone option, the application of this leachate treatment alternative in isolation would not provide operational flexibility at the WCEC, as there would be no contingency process in place during periods of maintenance or downtime.



Option #4 – Off-site Effluent Discharge to City of Ottawa Sanitary Sewer

Application of this alternative would result in the effective treatment of leachate at the WCEC, having placed first in the comparative evaluation exercise. Implementation of Option #4 would include the use of well-proven, reliable technology, and would make use of available capacity at the City's ROPEC facility. Limitations associated with the implementation of this alternative at the WCEC in a stand-alone manner would include a lack of operational flexibility should volume and quality limits, as dictated by the City, be exceeded at any time and during periods of maintenance.

Option #5 – Truck Haulage Off-site to Alternative Wastewater Treatment Plant

This alternative is used for the disposal of leachate at many operating landfills and is a technically feasible, stand-alone option. The location of potential facilities and their ability to accept the volume and quality of leachate generated is unknown and it may be necessary to utilize more than one wastewater treatment plant. Given the uncertainties associated with this alternative, Option #5 is best implemented in the event of an emergency situation only (e.g., higher than normal leachate volumes, in the event of site maintenance disrupting regular leachate treatment method, etc.). As such, Option #5 has been removed from further consideration as a stand-alone alternative for leachate disposal.

4.3.2.2 System Alternative Analysis

Based upon the consideration of each of the four individual alternative leachate treatment methods in terms of their ability to function in a stand-alone manner, further consideration was given to the ability of Options #1, #2 and #4 to function in combination as systems to allow for operational flexibility. The following describes the opportunities and limitations associated with each of these individual options to function in a systems manner. There was no consideration given to the application of Options #2 and Option #4 in combination as these two alternatives provide redundant disposal for leachate.

Option #1 and Option #2

The implementation of Options #1 and #2 in tandem would allow for operational flexibility at the WCEC. This leachate treatment system would provide for a standing contingency plan, should treatment via evaporation be interrupted for any reason; it would have no limitations with respect to seasonality; and the area required for the tree stand would be much smaller than that required for the implementation of Option #1 alone, and so could be planted and constructed on-site. A pond for seasonal storage of pretreated leachate, prior to irrigation, is not anticipated to be a necessary component of this system.



The limitations associated with the implementation of this option would be similar to those described in association with the implementation of Option #2 in a stand-alone capacity. These would include: a high capital cost for the construction of the evaporator and a moderate impact on the visual environment from the combustion stack and vapour plume.

Option #1 and Option #4

The implementation of Options #1 and #4 in tandem would also allow for maximum operational flexibility at the WCEC. This leachate treatment system would provide for a standing contingency plan, should discharge to the City's sanitary sewer be interrupted for any reason; it would have no limitations with respect to seasonality; and the area required for the tree stand would be much smaller than that required for the implementation of Option #1 alone, and so could be planted and constructed on-site. A pond for seasonal storage of pretreated leachate, prior to irrigation, is not anticipated to be a necessary component of this system.

4.4 Preferred Alternative

Given the ranking of Option #4 – Off-site Effluent Discharge to City of Ottawa Sanitary Sewer as the highest ranked amongst the five leachate treatment alternatives in the comparative evaluation, and that operational flexibility at the WCEC would be enhanced by its implementation in combination with Option #1 – On-site Tree Irrigation, it can be concluded that the **Preferred** leachate treatment alternative for the WCEC is the implementation of Options #1 and #4 in combination.

The application of Option #1 and Option #2 – On-site Leachate Evaporation in combination would also be a viable means of disposing leachate, and is considered to be the **Contingency** system, should the preferred alternative not be able to be implemented for any reason.

Option #5

Truck Haulage Off-site to Alternative Wastewater Treatment Plant would be implemented as an **Emergency** measure in the case of either combination, Options #1 and #4 or Options #1 and #2, being unable to operate.



Figures



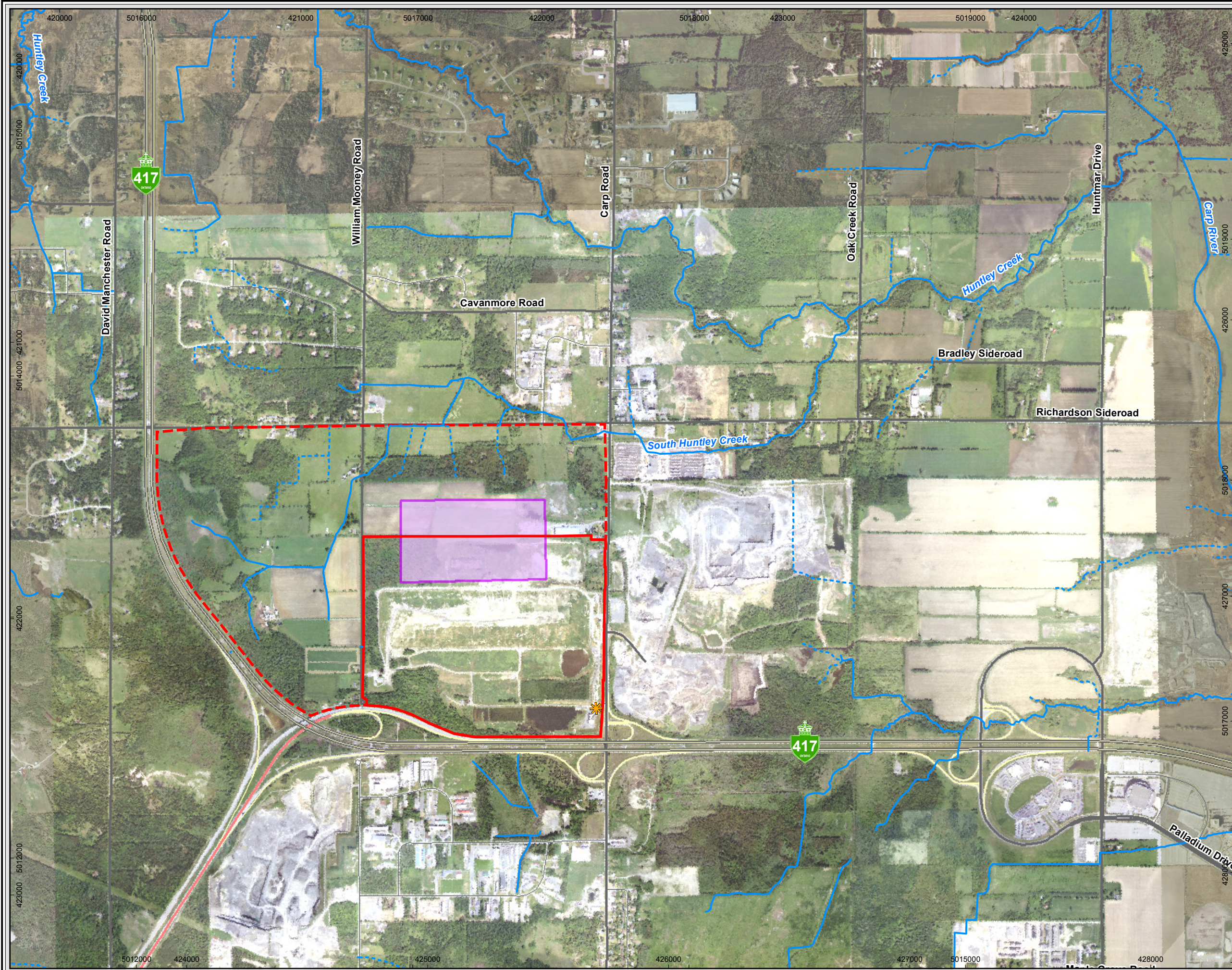

- Legend**
- Existing Forcemain Connection
 - Preferred Landfill Footprint
 - Study Area
 - Current Ottawa WMF Operations
 - Intermittent Stream
 - Permanent Stream

Basemapping from Ontario Ministry of Natural Resources
Orthophotography: 2005, 2008 and 2010

0 150 300 600
m
1:20,000
UTM Zone 17N, NAD 83

This drawing has been prepared for the use of AECOM's client and may not be used, reproduced or relied upon by third parties, except as agreed by AECOM and its client, as required by law or for use by governmental reviewing agencies. AECOM accepts no responsibility, and denies any liability whatsoever, to any party that modifies this drawing without AECOM's express written consent.

Waste Management of Canada Corporation
West Carleton Environmental Centre

**Preferred Landfill Footprint
and Surrounding Area**

November 2011
Project 60191228

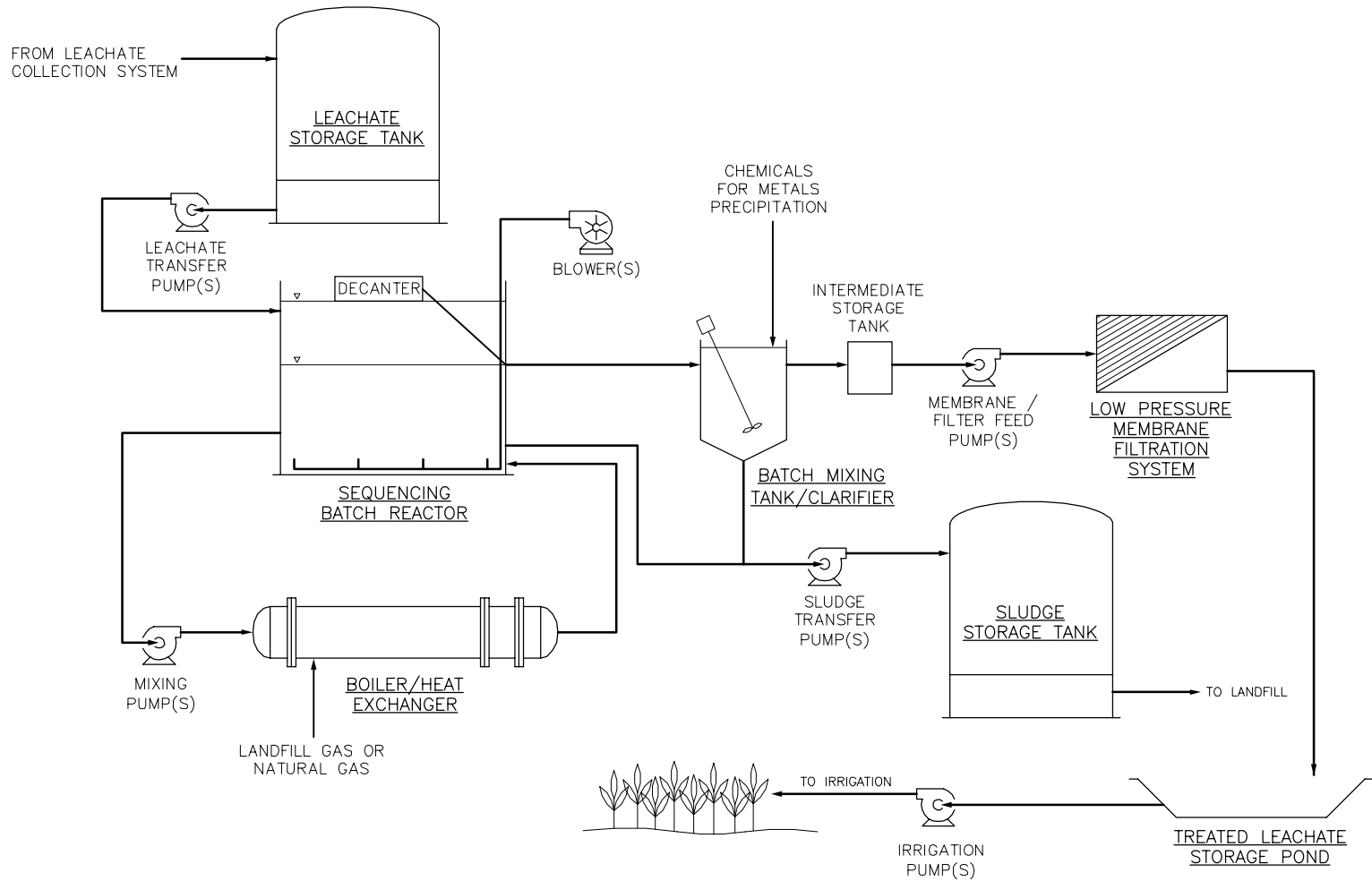

NOTE:
 1. SCHEMATIC INCLUDES TREATMENT OF LEACHATE ON-SITE PRIOR TO IRRIGATION.

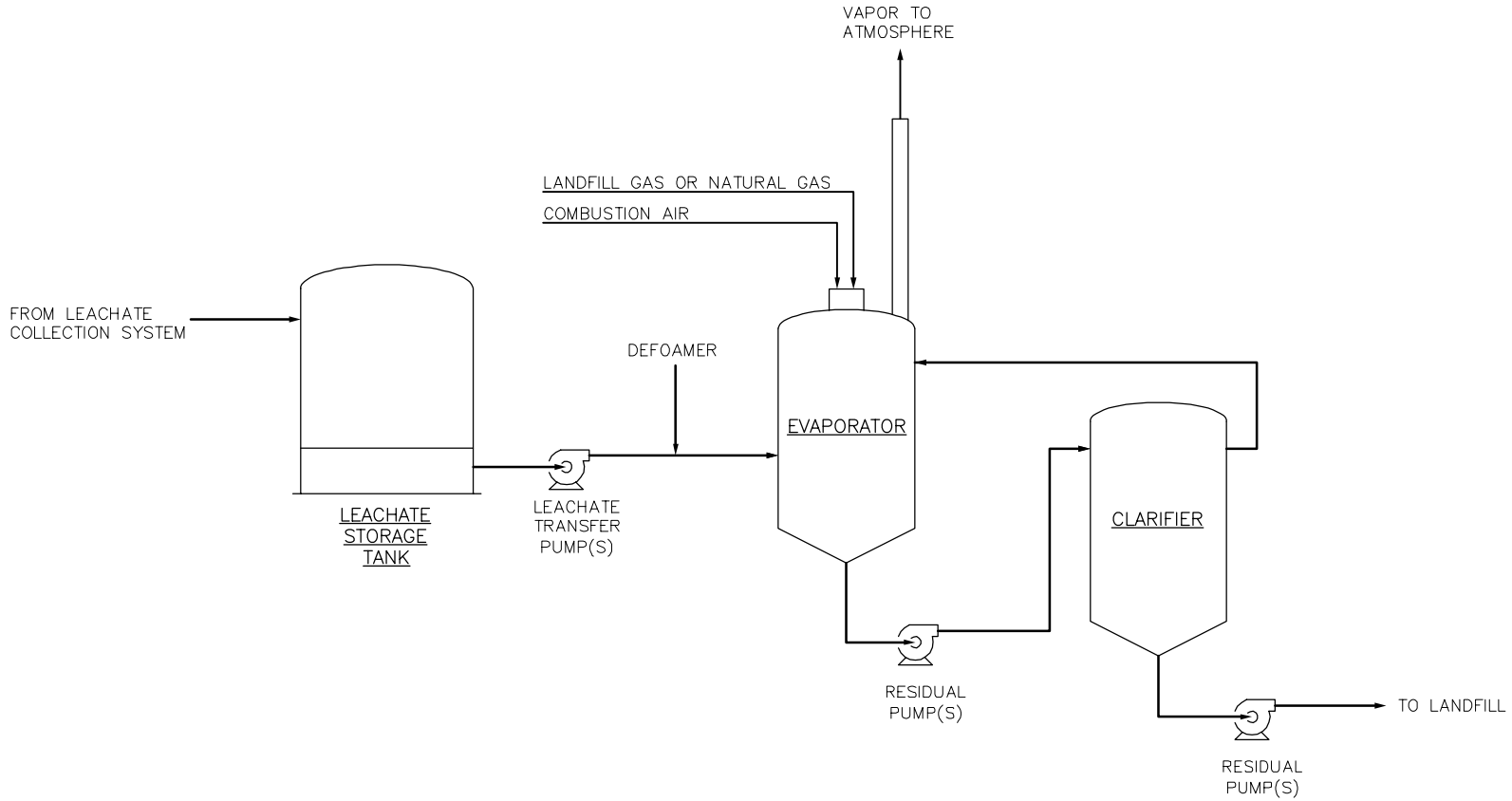

FIGURE 2

ON-SITE TREE IRRIGATION

WASTE MANAGEMENT OF CANADA CORPORATION
 WEST CARLETON ENVIRONMENTAL CENTRE

FILE NAME: FIGURES.dwg	DRN DPE	PROJECT NO. 60218152	DATE 11/11	FIGURE NO. FIG-2
---------------------------	------------	-------------------------	---------------	---------------------



NOTE:
1. TREATMENT OF LEACHATE PRIOR
TO EVAPORATION PROCESS IS
NOT SHOWN HERE.



FIGURE 3

ON-SITE LEACHATE EVAPORATION

WASTE MANAGEMENT OF CANADA CORPORATION
WEST CARLETON ENVIRONMENTAL CENTRE

FILE NAME: FIGURES.dwg	DRN DPE	PROJECT NO. 60218152	DATE 11/11	FIGURE NO. FIG-3
---------------------------	------------	-------------------------	---------------	---------------------

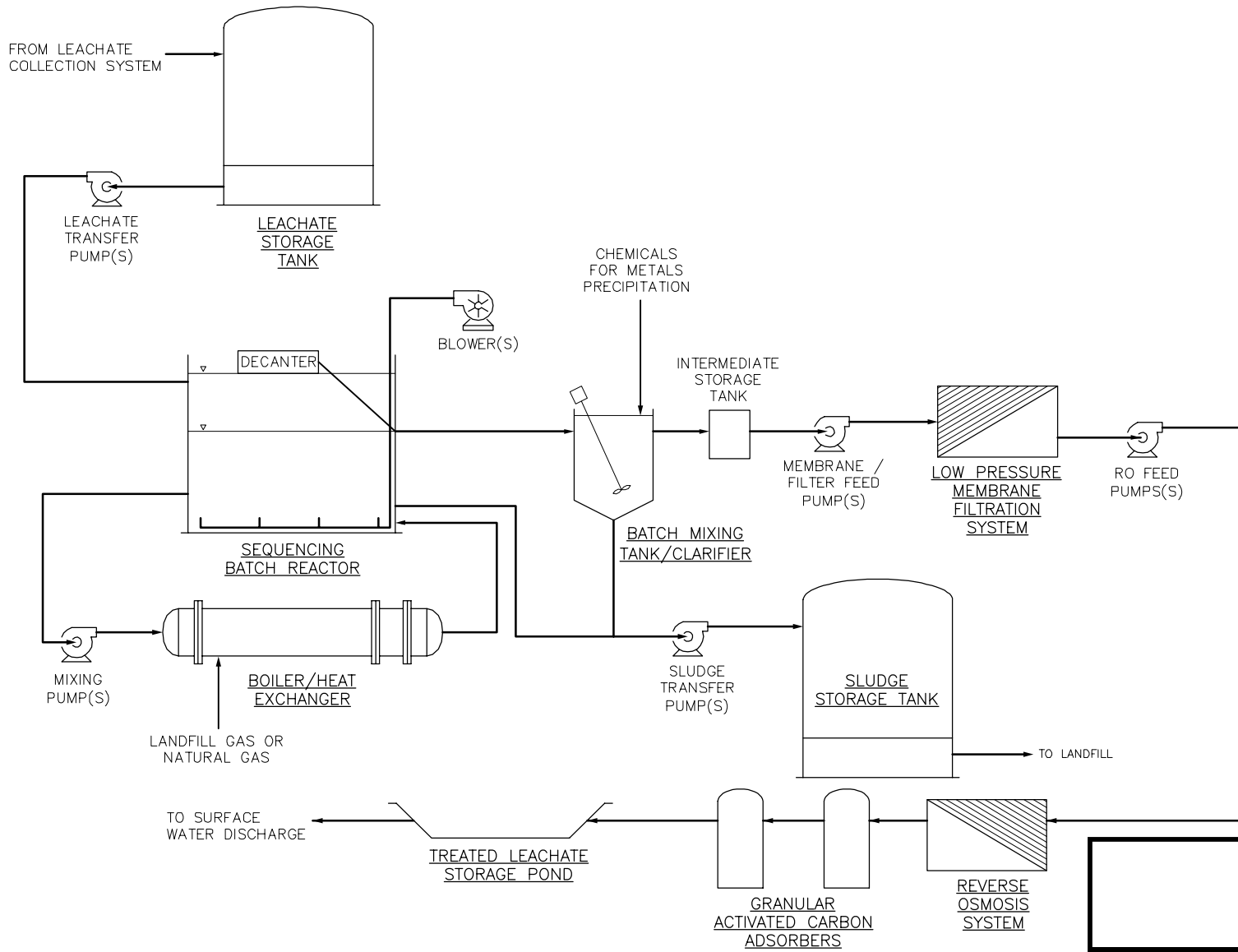

FIGURE 4
 OFF-SITE EFFLUENT
 DISCHARGE TO
 SURFACE WATER

WASTE MANAGEMENT OF CANADA CORPORATION
 WEST CARLETON ENVIRONMENTAL CENTRE

FILE NAME: FIGURES.dwg	DRN DPE	PROJECT NO. 60218152	DATE 11/11	FIGURE NO. FIG-4
---------------------------	------------	-------------------------	---------------	---------------------

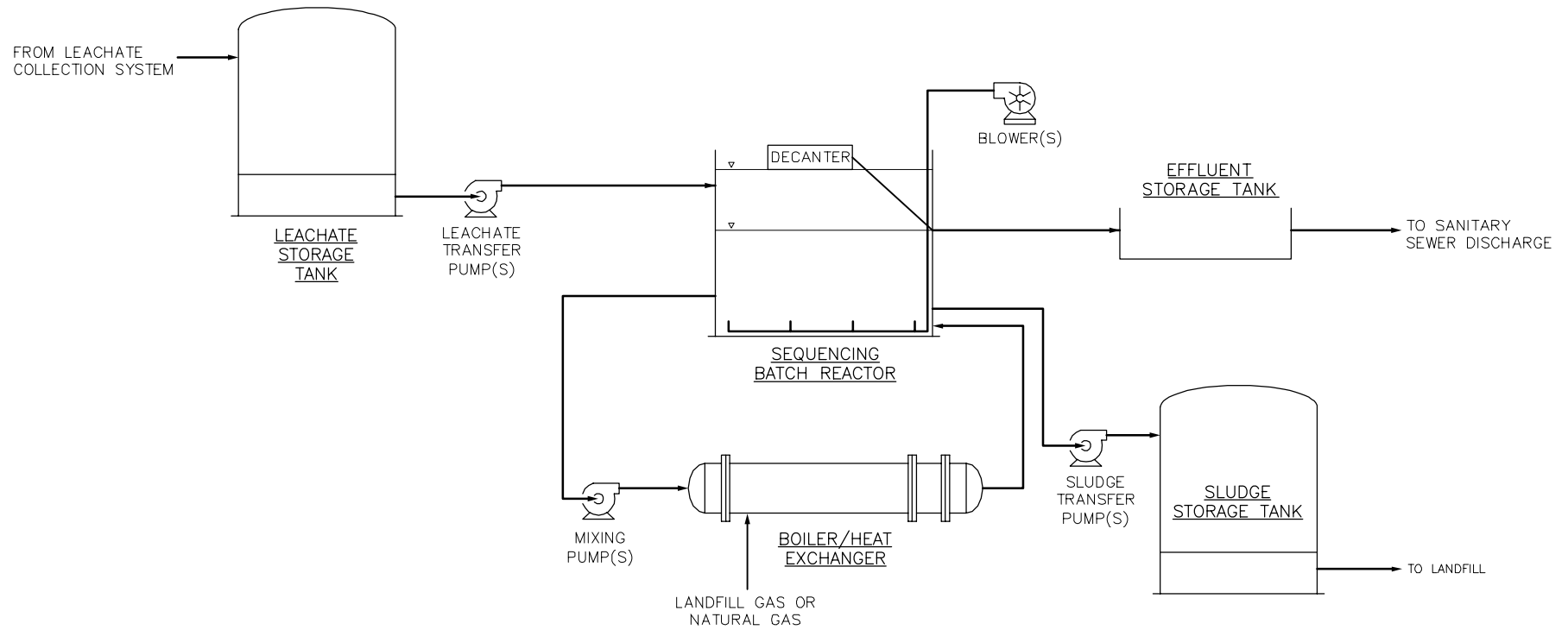
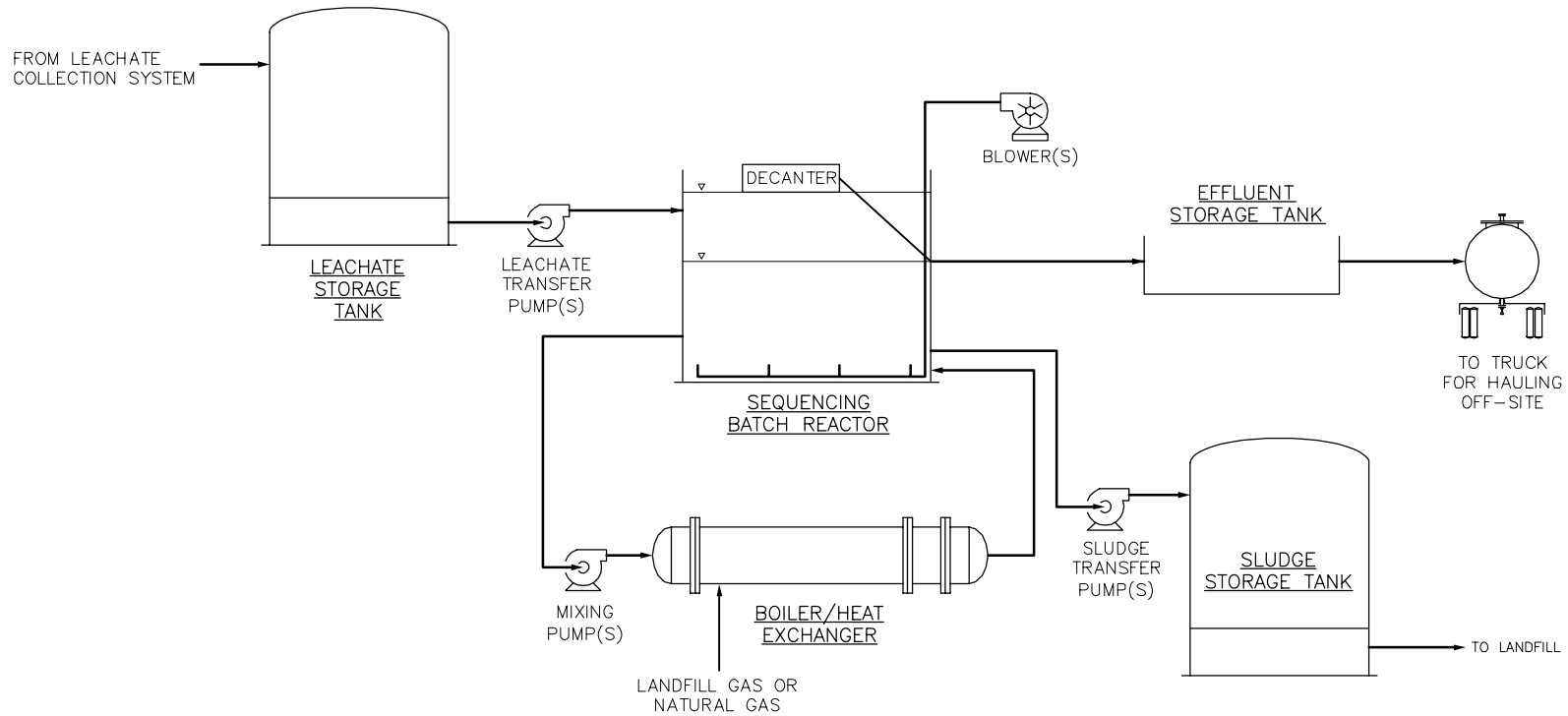

FIGURE 5
**OFF-SITE EFFLUENT
 DISCHARGE TO
 CITY OF OTTAWA SANITARY SEWER**
 WASTE MANAGEMENT OF CANADA CORPORATION
 WEST CARLETON ENVIRONMENTAL CENTRE

FILE NAME: FIGURES.dwg	DRN DPE	PROJECT NO. 60218152	DATE 11/11	FIGURE NO. FIG-5
---------------------------	------------	-------------------------	---------------	---------------------



NOTE:
 1. SCHEMATIC INCLUDES TREATMENT
 OF LEACHATE ON-SITE PRIOR TO
 HAULAGE OFF-SITE FOR DISPOSAL.



FIGURE 6
**TRUCK HAULAGE OFF-SITE
 TO ALTERNATIVE
 WASTEWATER TREATMENT PLANT**

WASTE MANAGEMENT OF CANADA CORPORATION
 WEST CARLETON ENVIRONMENTAL CENTRE

FILE NAME: FIGURES.dwg	DRN DPE	PROJECT NO. 60218152	DATE 11/11	FIGURE NO. FIG-6
---------------------------	------------	-------------------------	---------------	---------------------



Appendix A

Facility Sizing Calculations



Appendix A. Facility Sizing Calculations

Calculation of Storage Lagoon Volume Requirement

Assumptions	Period of storage:	6 months
		182.5 days
	Leachate flow rate:	5.1 L/s
	(5.1 L/s x 86,400 s/day x 182.5 days)/1,000	
Volume =	L/m ³ =	80,417 cubic meters

Calculation of Poplar Tree Space Requirement for Leachate Irrigation

Assumptions	Annual leachate uptake rate:	4,164 L/tree
	Leachate flow rate:	5.1 L/s maximum annual average
	Annual leachate volume:	160,833,600 L/year maximum annual average
	Tree planting density:	4,800 per hectare
	Number of poplar trees required =	
	Annual leachate volume / leachate uptake	
	rate per tree =	
		38,629
Space requirement =	number of poplar trees / tree planting	
	density =	8.0 hectares